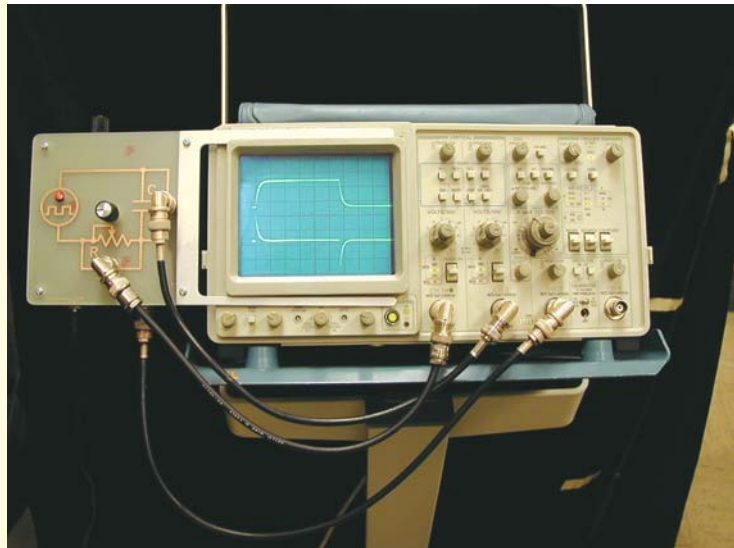

## CHAPTER 18

**Learning Objectives**

- Circle Diagram of a Series Circuit
- Rigorous Mathematical Treatment
- Constant Resistance but Variable Reactance
- Properties of Constant Reactance But Variable Resistance Circuit
- Simple Transmission Line Circuit

**CIRCLE  
DIAGRAMS**

Combinations of R and C circuits

### 18.1. Circle Diagram of a Series Circuit

Circle diagrams are helpful in analysing the operating characteristics of circuits, which, under some conditions, are used in representing transmission lines and a.c. machinery (like induction motor etc.)

Consider a circuit having a constant reactance but variable resistance varying from zero to infinity and supplied with a voltage of constant magnitude and frequency (Fig. 18.1).

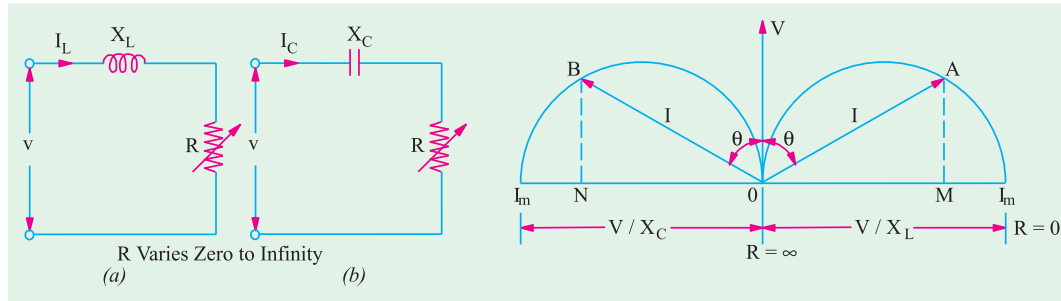

Fig. 18.1

Fig. 18.2

If  $R = 0$ , then  $I = V/X_L$  or  $V/X_C$  and has maximum value. It will lag or lead the voltage by  $90^\circ$  depending on whether the reactance is inductive or capacitive. In Fig. 18.2, angle  $\theta$  represents the phase angle. If  $R$  is now increased from its zero value, then  $I$  and  $\theta$  will both decrease. In the limiting case, when  $R = \infty$ , then  $I = 0$  and  $\theta = 0^\circ$ . It is found that the locus of end point of current vector  $OA$  or  $OB$  represents a semi-circle with diameter equal to  $V/X$  as shown in Fig. 18.2. It can be proved thus :

$$I = V/Z \text{ and } \sin \theta = X/Z \text{ or } Z = X/\sin \theta \therefore I = V \sin \theta / X$$

For constant value of  $V$  and  $X$ , the above is the polar equation of a circle of diameter  $V/X$ . This equation is plotted in Fig. 18.2. Here,  $OV$  is taken as reference vector. It is also seen that for inductive circuit, the current semi-circle is on the right-hand side of reference vector  $OV$  so that current vector  $OA$  lags by  $\theta^\circ$ . The current semi-circle for  $R-C$  circuit is drawn on the left hand side of  $OV$  so that current vector  $OB$  leads  $OV$  by  $\theta^\circ$ . It is obvious that  $AM = I \cos \theta$ , hence  $AM$  represents, on a suitable scale, the power consumed by the  $R-L$  circuit, Similarly,  $BN$  represents the power consumed by the  $R-C$  circuit.

### 18.2. Rigorous Mathematical Treatment

We will again consider both  $R-L$  and  $R-C$  circuits. The voltage drops across  $R$  and  $X_L$  (or  $X_C$ ) will be  $90^\circ$  out of phase with each other. Hence, for any given value of resistance, the vector diagram for the two voltage drops (*i.e.*  $IR$  and  $IX$ ) is a rightangled triangle having applied voltage as the hypotenuse.

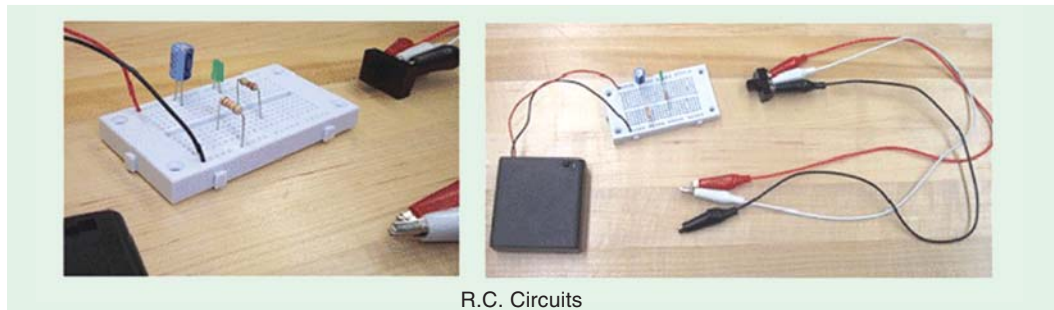

R.C. Circuits



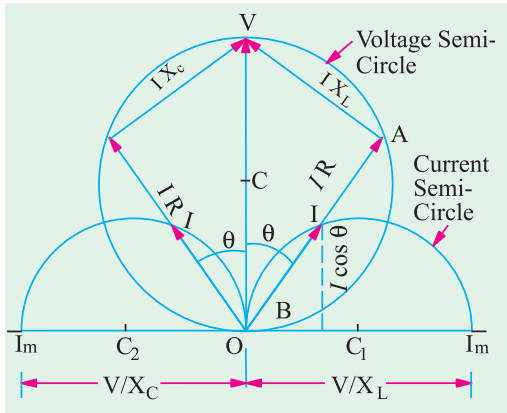

Fig. 18.3

For a constant applied voltage and reactance, the vector diagrams for different values of  $R$  are represented by a series of right-angled triangles having common hypotenuse as shown in Fig. 18.3. The locus of the apex of the right-angled voltage triangles is a semicircle described on the hypotenuse. The voltage semi-circle for  $R$ - $L$  circuit ( $OAV$ ) is on the right and for  $R$ - $C$  circuit ( $OBV$ ) on the left of the reference vector  $OV$  as shown in Fig. 18.3.

The foci of end points of current vectors are also semi-circles as shown but their centres lie on the opposite sides of and in an axis perpendicular to the reference vector  $OV$ .

**(ii) R-L Circuit** [Fig. 18.1 (a)]

The co-ordinates of point  $A$  with respect to the origin  $O$  are

$$y = I \cos \theta = \frac{V}{Z} \cdot \frac{R}{Z} = V \frac{R}{Z^2}; x = I \sin \theta = \frac{V}{Z} \cdot \frac{X_L}{Z} = V \frac{X_L}{Z^2} \quad \dots (i)$$

Squaring and adding, we get

$$x^2 + y^2 = \frac{VR}{R^2 + X_L^2} + \frac{VX_L}{R^2 + X_L^2} = \frac{V^2(R^2 + X_L^2)}{(R^2 + X_L^2)^2} = \frac{V^2}{R^2 + X_L^2}$$

From (i) above,  $\frac{VX_L}{x} = R^2 + X_L^2$   $\implies x^2 + y^2 = \frac{V^2}{VX_L/x} = \frac{xV}{X_L}$

$$\therefore x^2 + y^2 = \frac{xV}{X_L} \quad \text{or} \quad y^2 = x \left[ \frac{V}{2X_L} \right]^2 - \frac{V^2}{4X_L^2}$$

This is the equation of a circle, the co-ordinates of the centre of which are  $y = 0, x = V/2 X_L$  and whose radius is  $V/2X_L$ .

**(ii) R-C Circuit.** In this case it can be similarly proved that the locus of the end point of current vector is a semi-circle. The equation of this circle is

$$y^2 = x \left[ \frac{V}{2X_C} \right]^2 - \frac{V^2}{4X_C^2}$$

The centre has co-ordinates of  $y = 0, x = -V/2X_C$ .



**18.3. Constant Resistance But Variable Reactance**

Fig. 18.4 shows two circuits having constant resistance but variable reactance  $X_L$  or  $X_C$  which vary from zero to infinity. When  $X_L = 0$ , current is maximum and equals  $V/R$ . For other values,  $I = V/\sqrt{R^2 + X_L^2}$ . Current becomes zero when  $X_L = \infty$ . As seen from Fig. 18.5, the end point of the current vector describes a semi-circle with radius  $OC = V/2R$  and centre lying in the reference sector *i.e.* voltage vector  $OV$ . For  $R$ - $C$  circuit, the semi-circle lies to the left of  $OV$ . As before, it may be proved that the equation of the circle shown in Fig. 18.5 is

$$x^2 + y^2 = \frac{V^2}{4R^2}$$

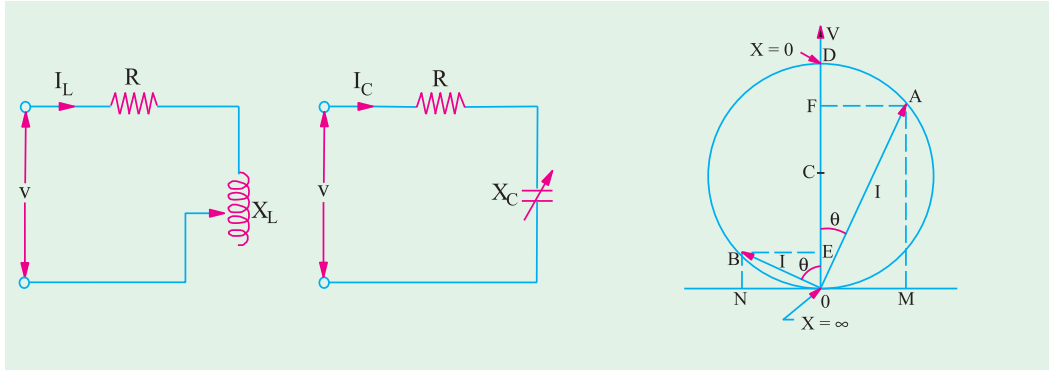

Fig. 18.4

Fig. 18.5

The co-ordinates of the centre are  $x = 0$ ,  $y = V/2R$  and radius  $= V/2R$ .

As before, power developed would be maximum when current vector makes an angle of  $45^\circ$  with the voltage vector  $OV$ . In that case, current is  $I_m / \sqrt{2}$  and  $P_m = VI_m / 2$ .

#### 18.4. Properties of Constant Reactance But Variable Resistance Circuit

From the circle diagram of Fig. 18.3, it is seen that circuits having a constant reactance but variable resistance or *vice-versa* have the following properties :

- (i) the current has limiting value
- (ii) the power supplied to the circuit has a limiting value also
- (iii) the power factor corresponding to maximum power supply is  $0.707 (= \cos 45^\circ)$

Obviously, the maximum current in the circuit is obtained when  $R = 0$ .

$$\therefore \begin{aligned} I_m &= V / X_L = V / \omega L \\ &= -V / X_C = -\omega VC \end{aligned}$$

... for R-L circuit

... for R-C circuit

Now, power  $P$  taken by the circuit is  $VI \cos \theta$  and if  $V$  is constant, then  $P \propto I \cos \theta$ . Hence, the ordinates of current semi-circles are proportional to  $I \cos \theta$ . The maximum ordinate possible in the semi-circle represents the maximum power possible in the circuit. The maximum ordinate passes through the centre of semi-circle so that current vector makes an angle of  $45^\circ$  with both the diameter and the voltage vector  $OV$ . Obviously, power factor corresponding to maximum power intake is  $\cos 45^\circ = 0.707$ .

Maximum power,

$$P_m = V \times AB = V \times \frac{I_m}{2} = \frac{1}{2} VI_m$$

Now, for R-L circuit,  $I_m = V/X_L$

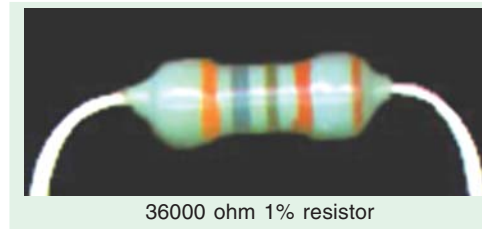

36000 ohm 1% resistor

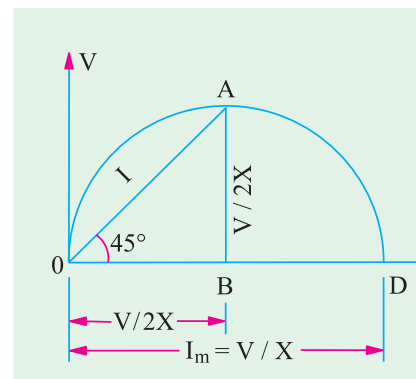

Fig. 18.6

$$\therefore P_m = \frac{V^2}{2X_L} = \frac{V^2}{2L}$$

$$\text{For } R\text{-}C \text{ circuit } P_m = \frac{V^2}{2X_C} = \frac{V^2\omega C}{2}$$

As said above, at maximum power,  $\theta = 45^\circ$ , hence vector triangle for voltages is an isosceles triangle which means that voltage drops across resistance and reactance are each equal to  $0.707$  of supply voltage *i.e.*  $V/\sqrt{2}$ . As current is the same, for maximum power, resistance equals reactance *i.e.*  $R = X_L$  (or  $X_C$ ).

Hence, the expression representing maximum power may be written as  $P_m = V^2/2R$ .

### 18.5. Simple Transmission Line Circuit

In Fig. 18.7 (a) is shown a simple transmission circuit having negligible capacitance and reactance.  $R$  and  $X_L$  represent respectively the resistance and reactance of the line and  $R_L$  represents load resistance.

If  $R$  and  $X_L$  are constant, then as  $R_L$  is varied, the current  $AM$  follows the equation  $I = (V/X) \sin \theta$  (Art. 18.1). The height  $AM$  in Fig. 18.7 (b) represents the power consumed by the circuit but, in the present case, this power is consumed both in  $R$  and  $R_L$ . The power absorbed by each resistance can be represented on the circle diagram.

In Fig. 18.7 (b),  $OB$  represents the line current when  $R_L = 0$ . The current  $OB = V/\sqrt{(R^2 + X_L^2)}$  and power factor is  $\cos \theta_1$ . The ordinate  $BN$  then represents on a different scale the power dissipated in  $R$  only.  $OA$  represents current when  $R_L$  has some finite value *i.e.*  $OA = V/\sqrt{(R+R_L)^2 + X_L^2}$ . The ordinate  $AM$  represents total power dissipated, out of which  $ME$  is consumed in  $R$  and  $AE$  in  $R_L$ .

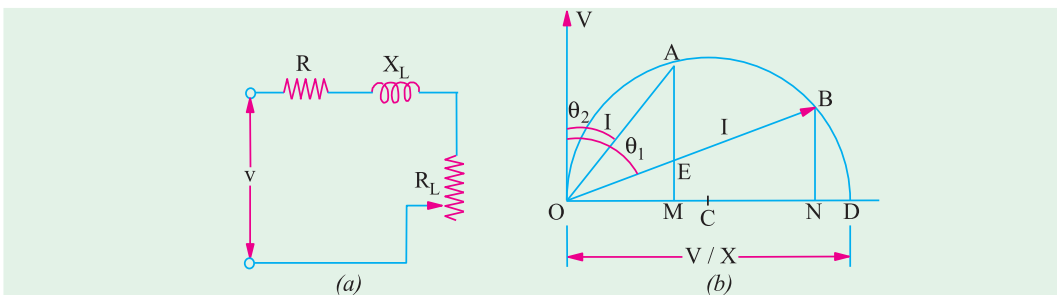

Fig. 18.7

In fact, if  $OA^2 \times R_L (= AE)$  is considered to be the output of the circuit (the power transmitted by the line), then

$$\eta = \frac{AE}{AM}$$

With  $R$  and  $X_L$  constant, the maximum power that can be transmitted by such a circuit occurs when the extremity of current vector  $OA$  coincides with the point of tangency to the circle of a straight line drawn parallel to  $OB$ . Obviously,  $V$  times  $AE$  under these conditions represents the maximum power and the power factor at that time is  $\cos \theta_2$ .

**Example 18.1.** A circuit consists of a reactance of  $5 \Omega$  in series with a variable resistance. A constant voltage of  $100 V$  is applied to the circuit. Show that the current locus is circular. Determine (a) the maximum power input to the circuit (b) the corresponding current, p.f. and value of the resistance. (Electrical Science II, Allahabad Univ. 1992)

**Solution.** For the first part, please refer to Art. 18.1

$$(a) I_m = V/X = 100/5 = 20 \text{ A}; P_m = \frac{1}{2} VI_m = \frac{1}{2} \times 100 \times 20 = \mathbf{1000 \text{ W}}$$

(b) At maximum power input, current is =  $OA$  (Fig. 18.6)

$$\therefore OA = I_m / \sqrt{2} = 20 / \sqrt{2} = 14.14 \text{ A}; p.f. = \cos 45^\circ = \mathbf{0.707}; R = X = \mathbf{5 \Omega}$$

**Example 18.2.** If a coil of unknown resistance and reactance is connected in series with a 100-V, 50-Hz supply, the current locus diagram is found to have a diameter of 5 A and when the value of series resistor is  $15 \Omega$ , the power dissipated is maximum. Calculate the reactance and resistance of the coil and the value of the maximum power in the circuit and the maximum current.

**Solution.** Let the unknown resistance and reactance of the coil be  $R$  and  $X$  respectively

$$\text{Diameter} = V/X \quad \therefore 5 = 100/X \quad \text{or} \quad X = \mathbf{20 \Omega}$$

Power is maximum when total resistance = reactance

$$\text{or } 15 + R = 20 \quad \therefore R = \mathbf{5 \Omega}$$

$$\text{Maximum power } P_m = V^2/2X = 100^2/2 \times 20 = \mathbf{250 \text{ W}}$$

$$\text{Maximum current } I_m = 100 / \sqrt{(20^2 + 5^2)} = \mathbf{4.85 \text{ A}}$$

**Example 18.3.** A constant alternating sinusoidal voltage at constant frequency is applied across a circuit consisting of an inductance and a variable resistance in series. Show that the locus diagram of the current vector is a semi-circle when the resistance is varied between zero and infinity.

If the inductance has a value of 0.6 henry and the applied voltage is 100 V at 25 Hz, calculate (a) the radius of the arc (in amperes) and (b) the value of variable resistance for which the power taken from the mains is maximum and the power factor of the circuit at the value of this resistance.

$$\text{Solution. } X_L = \omega L = 0.6 \times 2\pi \times 25 = 94.26 \Omega$$

$$(a) \text{ Radius} = V/2 X_L = 100/2 \times 4.26 = \mathbf{0.531 \text{ A}}$$

**Example 18.4.** A resistor of  $10 \Omega$  is connected in series with an inductive reactor which is variable between  $2 \Omega$  and  $20 \Omega$ . Obtain the locus of the current vector when the circuit is connected to a 250-V supply. Determine the value of the current and the power factor when the reactance is (i)  $5 \Omega$  (ii)  $10 \Omega$  (iii)  $15 \Omega$ . (Basic Electricity, Bombay Univ.)

**Solution.** As discussed in Art. 18.3, the end point of current vector describes a semi-circle whose diameter (Fig. 18.8) equals  $V/R = 250/10 = 25 \text{ A}$  and whose centre lies to right side of the vertical voltage vector  $OV$ .

$$I_{max} = 250 / \sqrt{10^2 + 2^2} = 24 \text{ A}; \theta = \tan^{-1} (2/10) = 11.3^\circ;$$

$$I_{min} = 250 / \sqrt{10^2 + 20^2} = 11.2 \text{ A}; \theta = \tan^{-1} (20/10) = 63.5^\circ$$

$$(i) \theta_1 = \tan^{-1} (5/10) = 26.7^\circ, p.f. = \cos 26.7^\circ = 0.89$$

$$I = OA = \mathbf{22.4 \text{ A}}$$

$$(ii) \theta_2 = \tan^{-1} (10/10) = 45^\circ, p.f. = \cos 45^\circ = \mathbf{1};$$

$$I = OB = \mathbf{17.7 \text{ A}}$$

$$(iii) \theta_3 = \tan^{-1} (15/10) = 56.3^\circ; p.f. = \cos 56.3^\circ = \mathbf{0.55};$$

$$I = OC = \mathbf{13.9 \text{ A}}$$

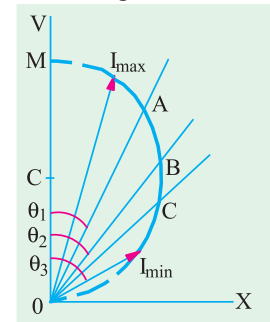

Fig. 18.8

**Example 18.5.** A voltage of  $100 \sin 10,000 t$  is applied to a circuit consisting of a  $1 \mu F$  capacitor in series with a resistance  $R$ . Determine the locus of the tip of the current phasor when  $R$  is varied from 0 to  $\infty$ . Take the applied voltage as the reference phasor.

(Network Theory and Design, AMIETE 1990)

**Solution.** As seen from Art. 18.2 the locus of the tip of the current phasor is a circle whose equation is

$$y^2 + x^2 - \frac{V}{2X_C}x = \frac{V^2}{4X_C^2}$$

We are given that  $V = V_m / \sqrt{2} = 100 / \sqrt{2} = 77.7 \text{ V}$

$$\omega = 10,000 \text{ rad/s}; X_C = 1/\omega \times C = 1/10,000 \times 1 \times 10^{-6} = 100 \text{ } \Omega \text{ C,}$$

$$(V/2 X_C)^2 = (77.7/2 \times 100)^2 = 0.151, \therefore y^2 + (x + 0.389)^2 = 0.151$$

**Example 18.6.** Prove that polar locus of current drawn by a circuit of constant resistance and variable capacitive reactance is circular when the supply voltage and frequency are constant.

If the constant resistance is  $10 \text{ } \Omega$  and the voltage is  $100 \text{ V}$ , draw the current locus and find the values of the current and p.f. when the reactance is (i)  $5.77 \text{ } \Omega$  (ii)  $10 \text{ } \Omega$  and (iii)  $17.32 \text{ } \Omega$ . Explain when the power will be maximum and find its value.

(Electromechanics, Allahabad Univ. 1992)

**Solution.** For the first part, please refer to Art. 18.3. The current semicircle will be drawn on the vertical axis with a radius  $OM = V/2 R = 100/2 \times 10 = 5 \text{ A}$  as shown in Fig. 18.9 (b)

(i)  $\theta_1 = \tan^{-1}(5.77/10) = 30^\circ$ ;  $\cos \theta_1 = 0.866$   
(lead) ; current =  $OA = 8.66 \text{ A}$

(ii)  $\theta_2 = \tan^{-1}(10/10) = 45^\circ$ ;  $\cos \theta_2 = 0.707$   
(lead) current =  $OB = 7.07 \text{ A}$

(iii)  $\theta_3 = \tan^{-1}(17.32/10) = 60^\circ$ ;  $\cos \theta_3 = 0.5$   
(lead) current =  $OC = 5 \text{ A}$

Power would be maximum for point B when  $\theta = 45^\circ$ ;  $I_m = V/R = 100/10 = 10 \text{ A}$

$$P_m = V \times OB \times \cos 45^\circ = V \times I_m \cos 45^\circ \times \cos$$

$$45^\circ = \frac{1}{2} VI_m = \frac{1}{2} \times 100 \times 10 = 500 \text{ W}$$

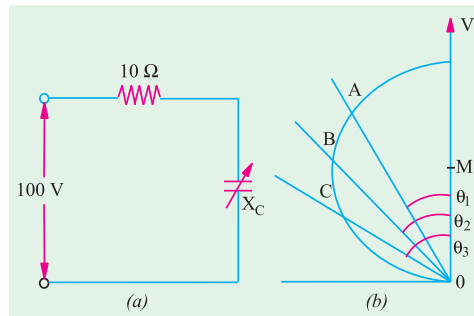

Fig. 18.9

**Example 18.7.** Prove that the polar locus of the current drawn by a circuit of constant reactance and variable resistance is circular when the supply voltage and frequency are constant.

If the reactance of such a circuit is  $25 \text{ } \Omega$  and the voltage  $250$ , draw the said locus and locate there on the point of maximum power and for this condition, find the power, current, power factor and resistance.

Locate also the point at which the power factor is  $0.225$  and for this condition, find the current, power and resistance.

(Basic Electricity, Bombay Univ.)

**Solution.** For the first part, please refer to Art. 18.3.

Radius of the current semi-circle is  $= V/2X = 250/2 \times 25 = 5 \text{ A}$ . As discussed in Art. 18.3, point A [Fig. 18.10 (a)] corresponds to maximum power.

$$\text{Now, } I_m = V/X = 250/25 = 10 \text{ A}; P_m = \frac{1}{2} VI_m = \frac{1}{2} \times 250 \times 10 = 1250 \text{ W}$$

$$\text{Current } OA = I_m/\sqrt{2} = 10/\sqrt{2} = 7.07 \text{ A}; \text{ p.f.} = \cos 45^\circ = 0.707.$$

$$\text{Under condition of maximum power, } R = X = 25 \text{ } \Omega.$$

$$\text{Now, } \cos \theta = 0.225;$$

$$\theta = \cos^{-1}(0.225) = 77^\circ$$

In Fig. 18.10 (b), current vector  $OA$  has been drawn at an angle of  $77^\circ$  with the vertical voltage vector  $OV$ .

By measurement, current

$$OA = 9.74 \text{ A}$$

By calculate,  $OA = I_m \cos$

$$13^\circ = 10 \times 0.974 = \mathbf{9.74 \text{ A}}$$

$$\text{Power} = VI \cos \theta = 250 \times 9.74 \times 0.225 = \mathbf{548 \text{ W}}$$

$$P = I^2 R; R = P/I^2 = 548/9.74^2 = \mathbf{5.775 \ \Omega}$$

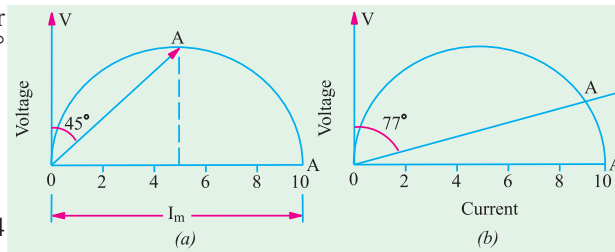

Fig. 18.10

**Example 18.8.** A non-inductive resistance  $R$ , variable between  $0$  and  $10 \ \Omega$ , is connected in series with a coil of resistance  $3 \ \Omega$  and reactance  $4 \ \Omega$  and the circuit supplied from a  $240\text{-V}$  a.c. supply. By means of a locus diagram, determine the current supplied to the circuit when  $R$  is (a) zero (b)  $5 \ \Omega$  and (c)  $10 \ \Omega$ . By means of the symbolic method, calculate the value of the current when  $R = 5 \ \Omega$ .

**Solution.** The locus of the current vector is a semi-circle whose centre is  $(0, V/2X)$  and whose radius is obviously equal to  $V/2X$ . Now,  $V/2X = 240/2 \times 4 = 30 \text{ A}$ .

Hence, the semi-circle is drawn as shown in Fig. 18.11 (b).

(a) Total resistance =  $3 \ \Omega$  and  $X = 4 \ \Omega$ .  $\therefore \tan \theta_1 = 4/2 \therefore \theta_1 = 53^\circ 8'$

Hence, current vector  $OA$  is drawn making an angle of  $53^\circ 8'$  with vector  $OV$ . Vector  $OA$  measures  $49 \text{ A}$ .

(b) Total resistance =  $3 + 5 = 8 \ \Omega$ .

Reactance =  $4 \ \Omega$ ;  $\tan \theta_2 = 4/8 = 0.5 \therefore \theta_2 = 26^\circ 34'$

Current vector  $OB$  is drawn at an angle of  $26^\circ 34'$  with  $OV$ . It measure  $27 \text{ A}$  (approx.)

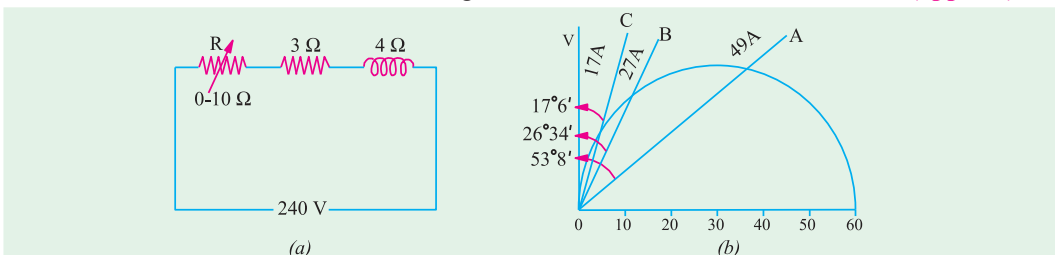

Fig. 18.11

(c) Total resistance =  $3 + 10 = 13 \ \Omega$ .

Reactance =  $4 \ \Omega$ ;  $\tan \theta_3 = 4/13 \therefore \theta_3 = 17^\circ 6'$

Current vector  $OC$  is drawn at an angle of  $17^\circ 6'$  with vector  $OA$ . It measures  $17 \text{ A}$ .

### Symbolic Method

$$I = \frac{240}{(5 + j3) + j4} = \frac{240}{8 + j4} = \frac{240}{8.96 \angle 26.5^\circ} = 26.7 \angle 26.5^\circ$$

**Note.** There is difference in the magnitudes of the currents and the angles as found by the two different methods. It is so because one has been found exactly by mathematical calculations, whereas the other has been measured from the graph.

**Example 18.9.** A circuit consisting of a  $50\text{-}\Omega$  resistor in series with a variable reactor is shunted by a  $100\text{-}\Omega$  resistor. Draw the locus of the extremity of the total current vector to scale and determine the reactance and current corresponding to the minimum overall power factor, the supply voltage being  $100 \text{ V}$ .

**Solution.** The parallel circuit is shown in Fig. 18.12 (a).



The resistive branch draws a fixed current  $I_2 = 100/100 = 1$  A. The current  $I_1$  drawn by the reactive branch is maximum when  $X_L = 0$  and its maximum value is  $= 100/50 = 2$  A and is in phase with voltage.

In the locus diagram of Fig. 18.12 (b), the diameter  $OA$  of the reactive current semi-circle is  $= 2$  A.  $OB$  is the value of  $I_1$  for some finite value of  $X_L$ .  $O'O$  represents  $I_2$ . Being in phase with voltage, it is drawn in phase with voltage vector  $OV$ . Obviously,  $O'B$  represents total circuit current, being the vector sum of  $I_1$  and  $I_2$ .

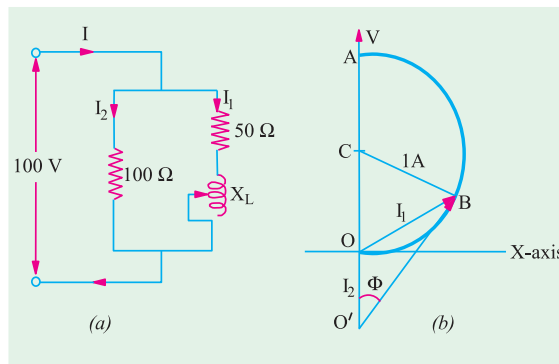

Fig. 18.12

The minimum power factor which corresponds to maximum phase difference between  $O'B$  and  $O'V$  occurs when  $O'B$  is tangential to the semi-circle. In that case,  $O'B$  is perpendicular to  $BC$ . It means that  $O'BC$  is a right-angled triangle.

Now,  $\sin \phi = BC / O'C = 1 / (1 + 1) = 0.5; \phi = 30^\circ$

$\therefore$  Minimum  $p.f. = \cos 30^\circ = 0.866$  (lag)

Current corresponding to minimum  $p.f.$  is  $O'B = O'C \cos \phi = 2 \times 0.866 = 1.732$  A.

Now,  $\Delta OBC$  is an equilateral triangle, hence  $I_1 = OB = 1$  A. Considering reactive branch,  $Z = 100/1 = 100 \Omega$ ,  $X_L = \sqrt{100^2 - 50^2} = 88.6 \Omega$

**Example 18.10.** A coil of resistance  $60 \Omega$  and inductance  $0.4$  H is connected in series with a capacitor of  $17.6 \mu F$  across a variable frequency source which is maintained at a fixed potential of  $120$  V. If the frequency is varied through a range of  $40$  Hz to  $80$  Hz, draw the complete current locus and calculate the following :

- (i) the resonance frequency, (ii) the current and power factor at  $40$  Hz and
- (iii) the current and power factor at  $80$  Hz.

(Elect. Circuits, South Gujarat Univ.)

**Solution.** (i)  $f_0 = 10^3 / 2\pi\sqrt{0.4 \times 17.6} = 60$  Hz.

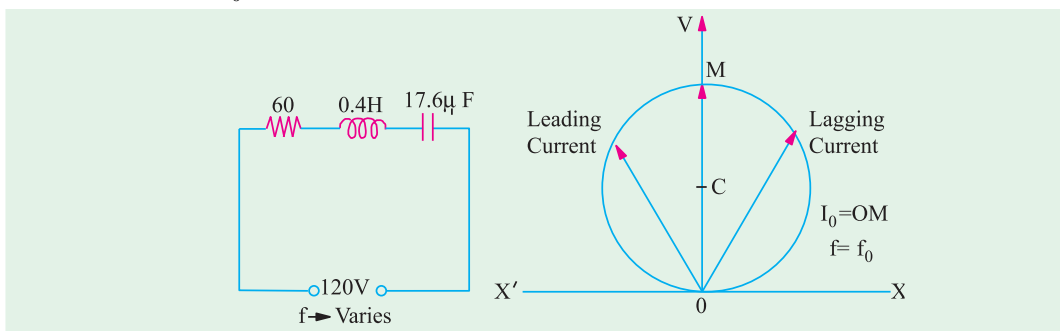

Fig. 18.13

(ii)  $f = 40$  Hz

$X_L = 2\pi \times 40 \times 0.4 = 100 \Omega$ ;  $X_C = 10^6 / 2\pi \times 40 \times 17.6 = 226 \Omega$

$X = 100 - 226 = -126 \Omega$  (capacitive);  $I = 120 / \sqrt{60^2 + (-126)^2} = 0.86$  A

$p.f. = \cos \theta = R/Z = 60/139.5 = 0.43$  (lead)

(iii)  $f = 80 \text{ Hz}$

$$X_L = 100 \times 2 = 200 \ \Omega ; X_C = 226/2 = 113 \ \Omega ; X = 200 - 113 = 87 \ \Omega \text{ (inductive)}$$

$$Z = \sqrt{R^2 + X^2} = \sqrt{60^2 + 87^2} = 105.3 \ \Omega$$

$$I = 120/105.3 = \mathbf{1.14 \text{ A}} ; \text{p.f. } \cos \theta = 60/105.3 = \mathbf{0.57 \text{ (lag)}}$$

### Tutorial Problems No. 18.1

1. A circuit having a constant resistance of  $60 \ \Omega$  and a variable inductance of 0 to  $0.4 \text{ H}$  is connected across a  $100\text{-V}$ ,  $50\text{-Hz}$  supply. Derive from first principles the locus of the extremity of the current vector. Find (a) the power and (b) the inductance of the circuit when the power factor is  $0.8$ .

**[(a) 107 W (v) 0.143 H] (App. Elect. London Univ.)**

2. A constant reactance of  $10 \ \Omega$  is connected in series with a variable resistor and the applied voltage is  $100 \text{ V}$ . What is (i) the maximum power dissipated and (ii) at what value of resistance does it occur?

**[(a) 500 W (ii) 10  $\Omega$ ] (City & Guilds London)**

3. A variable capacitance and a resistance of  $300 \ \Omega$  are connected in series across a  $240\text{-V}$ ,  $50\text{-Hz}$  supply. Draw the complex or locus of impedance and current as the capacitance changes from  $5 \mu\text{F}$  to  $30 \mu\text{F}$ . From the diagram, find (a) the capacitance to give a current of  $0.7 \text{ A}$  and (b) the current when the capacitance is  $10 \mu\text{F}$ .

**[19.2  $\mu\text{F}$ , 0.55A] (London Univ.)**

4. An a.c. circuit consists of a variable resistor in series with a coil, for which  $R = 20 \ \Omega$  and  $L = 0.1 \text{ H}$ . Show that when this circuit is supplied at constant voltage and frequency and the resistance is varied between zero and infinity, the locus diagram of the current vector is a circular arc. Calculate when the supply voltage is  $100 \text{ V}$  and the frequency  $50 \text{ Hz}$  (i) the radius (in amperes) of the arc (ii) the value of the variable resistor in order that the power taken from the mains may be a maximum.

**[(i) 1.592 A (ii) 11.4  $\Omega$ ] (London Univ.)**

5. A circuit consists of an inductive coil ( $L = 0.2 \text{ H}$ ,  $R = 20 \ \Omega$ ) in series with a variable resistor ( $0 - 200 \ \Omega$ ). Draw to scale the locus of the current vector when the circuit is connected to  $230\text{-V}$ ,  $50\text{-Hz}$  supply mains and the resistor is varied between  $0$  and  $200 \ \Omega$ . Determine (i) the value of the resistor which will give maximum power in the circuit, (ii) the power when the resistor is  $150 \ \Omega$ .

**[(i) 42.8  $\Omega$  (ii) 275 W] (London Univ.)**

6. A  $15 \ \mu\text{F}$  capacitor, an inductive coil ( $L = 0.135 \text{ H}$ ,  $R = 50 \ \Omega$ ) and a variable resistor are in series and connected to a  $230\text{-V}$ ,  $50\text{-Hz}$  supply.

Draw to scale the vector locus of the current when the variable resistor is varied between  $0$  and  $500 \ \Omega$ .

Calculate (i) the value of the variable resistor when the power is a maximum (ii) the power under these conditions.

**[(i) 120  $\Omega$  (ii) 155.5 W] (London Univ.)**

7. As a.c. circuit supplied at  $100 \text{ V}$ ,  $50\text{-Hz}$  consists of a variable resistor in series with a fixed  $100 \ \mu\text{F}$  capacitor.

Show that the extremity of the current vector moves on a circle. Determine the maximum power dissipated in the circuit the corresponding power factor and the value of the resistor.

**[157 W ; 0.707 ; 131.8  $\Omega$ ]**

8. A variable non-inductive resistor  $R$  of maximum value  $10 \ \Omega$  is placed in series with a coil which has a resistance of  $3 \ \Omega$  and reactance of  $4 \ \Omega$ . The arrangement is supplied from a  $240\text{-V}$  a.c. supply. Show that the locus of the extremity of the current vector is a semi-circle. From the locus diagram, calculate the current supplied when  $R = 5 \ \Omega$ .

**[26.7 A]**

9. A  $20\text{-}\Omega$  reactor is connected in parallel with a series circuit consisting of a reactor of reactance  $10 \ \Omega$  and a variable resistance  $R$ . Prove that the extremity of the total current vector moves on a circle. If the supply voltage is constant at  $100 \text{ V}$  (r.m.s.), what is the maximum power factor? Determine also the value of  $R$  when the p.f. has its maximum value.

**[0.5 ; 17.3  $\Omega$ ]**