

CHAPTER 64

Learning Objectives

- What are Breakdown Devices ?
- Unijunction Transistor
- UJT Relaxation Oscillator
- Programmable UJT(PUT)
- Silicon Controlled Rectifier
- Comparison between Transistors and Thyristors
- Transient Effects in an SCR
- Phase Control
- Theft Alarm
- Emergency Lighting System
- Light Activated SCR (LASCR)
- The Shockley Diode
- Triac
- Diac
- Silicon Controlled Switch (SCS)

BREAKDOWN DEVICES

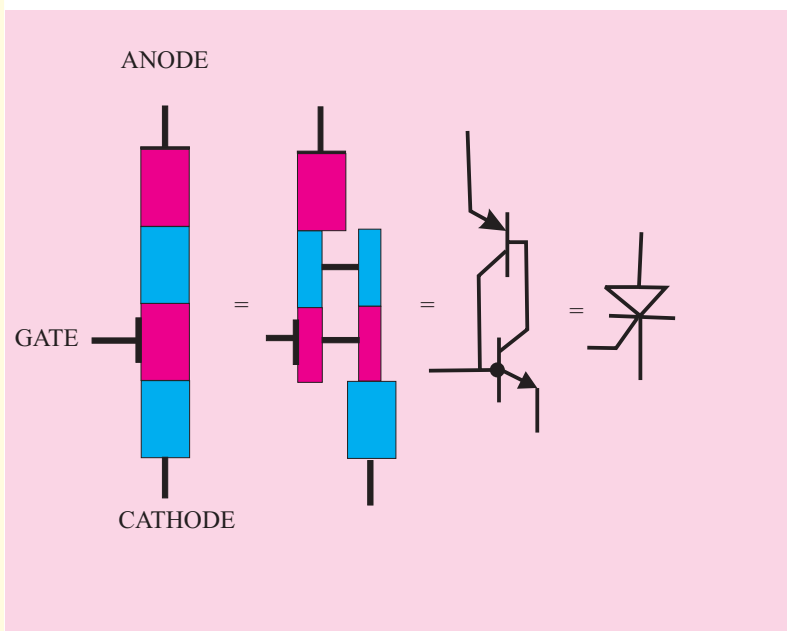

↑ The Silicon Controlled Rectifier, usually referred to as an SCR, is one of the family of semiconductors that includes transistors and diodes

64.1. What are Breakdown Devices ?

These are solid-state devices whose working depends on the *phenomenon of avalanche breakdown*. They are sometimes referred to by the generic name of *thyristor* which is a semiconductor switch whose bistable action depends on *P-N-P-N* regenerative feedback. We will discuss the following devices :

1. Unijunction Transistor (UJT).
2. Silicon Controlled Rectifier (SCR).
3. Light Activated SCR (LASCR).
4. Triac (short for 'triode ac').
5. Diac (short for 'diode ac').
6. Silicon Controlled Switch (SCS).



Cat-Transistor

These devices have two or more junctions and can be switched ON or OFF at *an extremely fast rate*. They are also referred to as *latching* devices. A latch is a kind of switch which initially once closed, remains closed until someone opens it.

64.2. Unijunction Transistor

Basically, it is a three-terminal silicon diode. As its name indicates, it has only one *P-N* junction. It differs from an ordinary diode in that it has *three* leads and it differs from a FET in that it has *no ability to amplify*. However, it has the ability *to control a large ac power with a small signal*. It also exhibits a negative resistance characteristic which makes it useful as an oscillator.

(a) Construction

It consists of a *lightly-doped silicon* bar with a heavily-doped *P*-type material alloyed to its one side (closer to B_2) for producing single *P-N* junction. As shown in Fig. 64.1 (a), there are three terminals : one emitter, E and two bases B_2 and B_1 at the top and bottom of the silicon bar. The emitter leg is drawn at an angle to the vertical and arrow points in the direction of *conventional* current when UJT is in the conducting state.

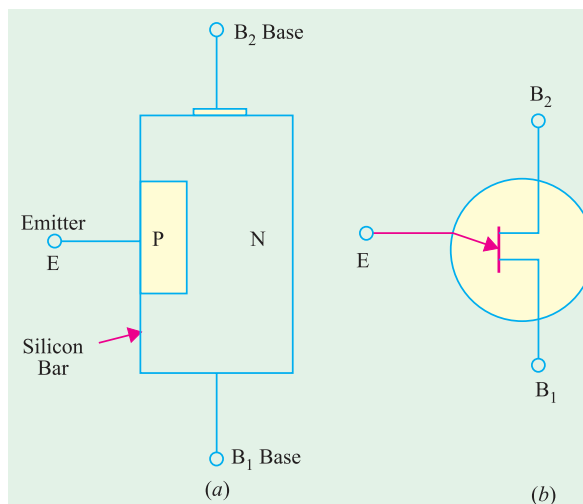

Fig. 64.1

(b) Interbase Resistance (R_{BB})

It is the resistance between B_2 and B_1 *i.e.* it is the total resistance of the silicon bar from one end to the other with emitter terminal open [Fig. 64.2 (a)].

From the equivalent circuit of Fig. 64.2 (b), it is seen that $R_{BB} = R_{B2} + R_{B1}$

It should also be noted that point A is such that $R_{B1} > R_{B2}$. Usually, $R_{B1} = 60\%$ of R_{B1} . The resistance R_{B1} has been shown as a variable resistor because its value varies inversely as I_E .

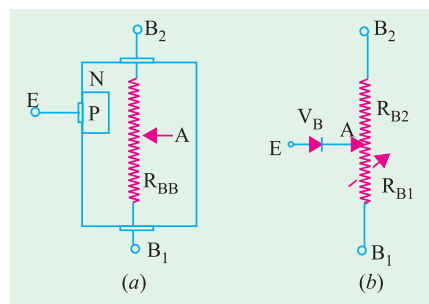

Fig. 64.2

(c) Intrinsic Stand-off Ratio

As seen from Fig. 64.3 (a), when a battery of 30 V is applied across $B_2 B_1$, there is a progressive fall of voltage over R_{BB} provided E is open. It is obvious from Fig. 64.3 (b) that emitter acts as a voltage-divider tap on fixed resistance R_{BB} .

With emitter open, $I_1 = I_2$, the interbase current is given by Ohm's Law.

$$I_1 = I_2 = V_{BB} / R_{BB}$$

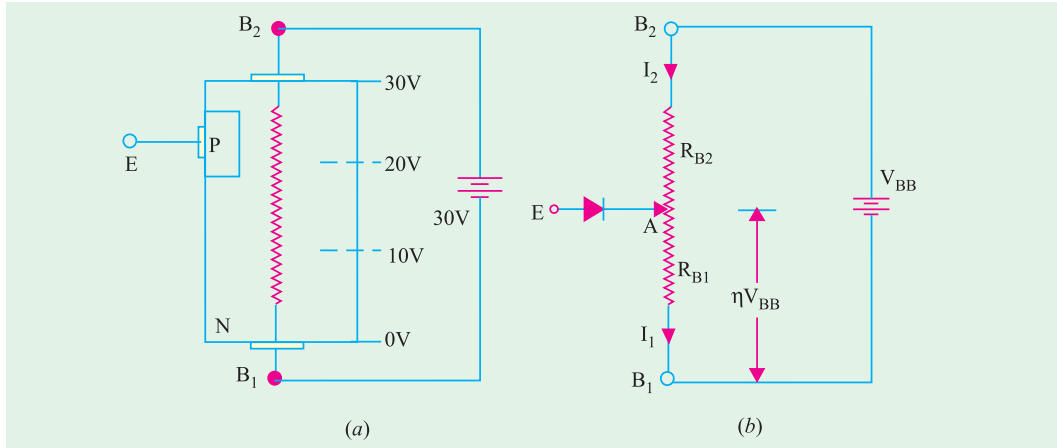

Fig. 64.3

For example, if $V_{BB} = 30 \text{ V}$ and $R_{BB} = 15 \text{ K}$, $I_1 = I_2 = 2 \text{ mA}$.

It may be noted that part of V_{BB} is dropped over R_{B2} and part on R_{B1} . Let us call the voltage drop across R_{B1} as V_A . Using simple voltage divider relationship,

$$V_A = V_{BB} \frac{R_{B1}}{R_{B1} + R_{B2}}$$

The voltage division factor is given a special symbol (η) and the name of '**intrinsic stand-off ratio**'.

$$\eta = \frac{R_{B1}}{R_{B1} + R_{B2}} \quad \therefore V_A = \eta V_{BB}$$

The intrinsic stand-off ratio is the property of the UJT and is always less than unity (0.5 to 0.85). If $V_{BB} = 30 \text{ V}$ and $\eta = 0.6$, then potential of point A with respect to point $B_1 = 0.6 \times 30 = 18 \text{ V}$. The remaining 12 V drop across R_{B2} .

(d) Operation

When V_{BB} is switched on, V_A is developed and **reverse-biases the junction**. If V_B is the barrier voltage of the P-N junction, then total reverse bias voltage is

$$= V_A + V_B = \eta V_{BB} + V_B$$

Value of V_B for Si is 0.7 V.

It is obvious that emitter junction will not become forward-biased unless its applied voltage V_E exceeds $(\eta V_{BB} + V_B)$. This value of V_E is called **peak-point voltage** V_P (Fig. 64.4). When $V_E = V_P$, emitter (peak current), I_P starts to flow through R_{B1} to ground (i.e. B_1). The UJT is then said to have been **fired** or turned ON. Due to the flow of $I_E (= I_P)$ through R_{B1} , number of charge carriers in R_{B1} is increased which **reduces its resistance**. As η depends on R_{B1} , **its value is also decreased**.

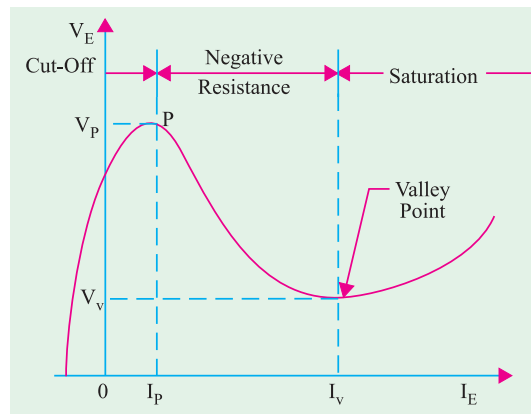

Fig. 64.4

Hence, we find that as V_E and hence I_E increases (beyond I_p), R_{B1} decreases, η decreases and V_A decreases. This decrease in V_A causes more emitter current to flow which causes a further reduction in R_{B1} , η and V_A . Obviously, the process is regenerative. V_A as well as V_E quickly drop as I_E increases. Since, V_E decreases when I_E increases, the UJT **possesses negative resistance**. Beyond the valley point, UJT is in saturation and V_E increases very little with an increasing I_E .

It is seen that only terminals E and B_1 are the active terminals whereas B_2 is the bias terminal *i.e.* it is meant only for applying external voltage across the UJT.

Generally, UJT is triggered into conduction by applying a suitable positive pulse at its emitter. It can be brought back to OFF state by applying a negative trigger pulse.

(e) Applications

One unique property of UJT is that it can be triggered by (or an output can be taken from) **any one of its three terminals**. Once triggered, the emitter current I_E of the UJT increases regeneratively till it reaches a limiting value determined by the external power supply. Because of this particular behaviour, UJT is used in a variety of circuit applications. Some of which are :

- 1. phase control
- 2. switching
- 3. pulse generation,
- 4. sine wave generator
- 5. sawtooth generator
- 6. timing and trigger circuits,
- 7. voltage or current regulated supplies.

Example 64.1. A given silicon UJT has an interbase resistance of 10 K. It has $R_{B1} = 6 K$ with $I_E = 0$. Find

- (a) UJT current if $V_{BB} = 20 V$ and V_E is less than V_p ,
- (b) η and V_A ,
- (c) peak point voltage, V_p .

(Applied Electronics-I, Punjab Univ. 1990)

Solution. (a) Since $V_E < V_p$, $I_E = 0$, because $P-N$ junction is reverse-biased.

$$\therefore I_1 = I_2 = \frac{V_{BB}}{R_{BB}} = \frac{20}{10K} = 2mA$$

$$(b) \eta = \frac{R_{B1}}{R_{BB}} = \frac{6}{10} = 0.6; V_A = \eta V_{BB} = 0.6 \times 20 = 12V$$

$$(c) V_p = \eta V_{BB} + V_B = 12 + 0.7 = 12.7 V$$

64.3. UJT Relaxation Oscillator

The relaxation oscillator shown in Fig. 64.5 consists of a UJT and a capacitor C which is charged through R as V_{BB} is switched on.

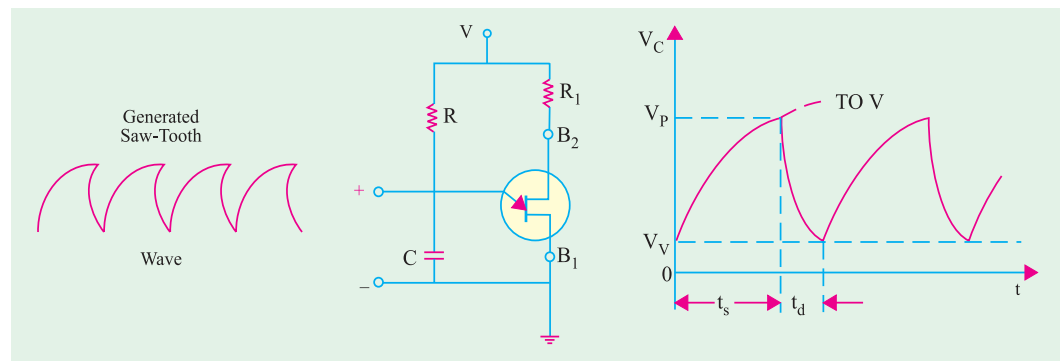

Fig. 64.5

When the capacitor voltage V_C reaches in time t_s the value of V_p , the UJT fires and rapidly discharges C via B_1 till the voltage falls below the minimum value V_v . The device then cuts off and

C starts to charge again. This cycle is repeated continuously thus generating a sawtooth waveform across C.

The inclusion of external resistances R_2 and R_1 in series with B_2 and B_1 (Fig. 64.6) provides **spike waveforms**. When the UJT fires, the sudden surge of current through B_1 causes a drop across R_1 which produces positive going spikes. Also, at the time of firing, fall of V_{BB1} causes I_2 to increase rapidly which generates negative going spikes across R_2 as shown in Fig. 64.6.

By switching over to different capacitors, frequency of the output waveform can be changed as desired.

Condition for Turn-ON and Turn-OFF

For satisfactory working of the above oscillator, following two conditions for the turn-on and turn-off of the UJT must be met. To ensure turn-on, R must not limit I_E at peak point to a value less than I_p . It means that

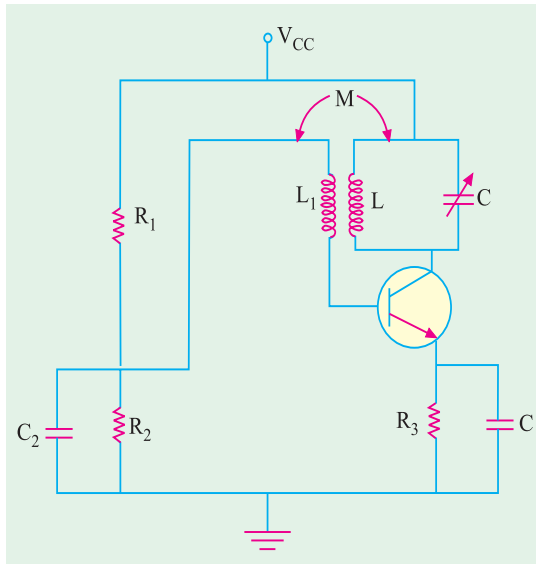

Fig. 64.6

$$V_{BB} - V_p > I_p R \text{ or } R < \frac{V_{BB} - V_p}{I_p}$$

To ensure turn-off of the UJT at valley point, R must be large enough to permit I_E (at valley point) to decrease below the specified value of I_v . In other words, drop across R at valley point must be less than IVR . Hence, condition for turn-off is

$$V_{BB} - V_v < I_v R \text{ or } R > \frac{V_{BB} - V_v}{I_v}$$

Hence, for reliable turn-on and turn-off of the UJT, R must be in the range

$$\frac{V_{BB} - V_p}{I_p} > R > \frac{V_{BB} - V_v}{I_v}$$

It should be noted that charging time constant of the capacitor for voltage V is $T = CR$ whereas discharging time constant is $T_d = CR_{B1}$.

The time required to charge upto V_p (called ramp rise time) is $t_s = T \log_e (V - V_v) / (V - V_p)$.

Similarly, time required by the capacitor to discharge from V_p to V_v is $t_d \cong T_d \log_e V_p / V_v$. The frequency of oscillation is given by $f = 1 / (t_s + t_d)$.

Example 64.2. The windshield wiper motor of an automobile is controlled by a UJT with $\eta = 0.6$. The capacitor has a value of $50 \mu F$ and the charging resistor is a series combination of $50 K$ resistor and a $500 K$ potentiometer. Determine the minimum and maximum number of blade strokes per minute possible with this arrangement.

Solution. The least value of time constant is $= 50,000 \times 50 \times 10^{-6} = 2.5$ second.

Maximum value of time constant when whole of potentiometer resistance is used is $= (50 + 500) \times 10^3 \times 50 \times 10^{-6} = 27.5$ second

Maximum blade strokes per minute $= 60 / 2.5 = 24$.

Minimum blade strokes per minute $= 60 / 27.5 = 2.2$.

Example 64.3. The oscillator circuit shown in Fig. 64.5 uses a UJT with $R_{BB} = 10 K$, $\eta = 0.6$, $V_B = 0.7 V$, $V = 50 V$, $R_1 = 90 K$, $R = 100 K$ and $C = 0.05 \mu F$. When UJT is in conduction, $R_{B1} = 10 \Omega$ and $V_v = V_B$. Find (i) ramp rise time, t_s (ii) approximate discharge time, t_d and (iii) frequency of oscillation.

Solution. $V_{BB} = V \cdot R_{BB} / (R_{BB} + R_1) = 50 \times 10 / 100 = 5 \text{ V}$
 $V_P = \eta V_{BB} + V_B = 0.6 \times 5 + 0.7 = 3.7 \text{ V}$
 $T = CR = 0.05 \times 10^{-6} \times 100 \times 10^3 = 5 \text{ ms}$

(i) The capacitor charges from $V_C = V_B = 0.7 \text{ V}$ to V_P towards V in the time t_s given by $t_s = T \log_e (V - V_V) / (V - V_P) = 5 \log_e (50 - 0.7) / (50 - 3.7) = \mathbf{0.315 \text{ ms}}$.

(ii) The discharge time, $t_d = CR_{B1} = 0.05 \times 10 = 0.5 \mu\text{s}$. The time taken by C to discharge from V_P to $V_V (= 0.7 \text{ V})$ towards 0 volt is

$$T_d \cong t_d \log_e V_P / V_V = 0.5 \log_e 3.7 / 0.7 = \mathbf{1.66 \mu\text{s}}$$

(iii) $f = 1 / (t_s + t_d) = 1 / (0.315 + 0.0016) = \mathbf{3.158 \text{ kHz}}$.

64.4. Programmable UJT (PUT)

Like a SCR, it is also a four-layer or PNPN device with a gate G as shown in Fig. 64.7. However, its gate is connected to the N -region adjacent to the anode A . This P - N junction controls the ON and OFF states of the PUT . The gate G is always biased positive with respect to cathode K . When anode voltage exceeds gate voltage by about 0.7 V , the P - N junction J_1 becomes forward-biased and the PUT turns ON. When the anode voltage falls below this level, the PUT is turned OFF.

As shown in Fig. 64.8 (a), gate bias can be adjusted to any bias level with the help of an external voltage divider circuit $R_2 - R_3$. Whenever anode voltage exceeds this **programmable level**, the PUT turns ON.

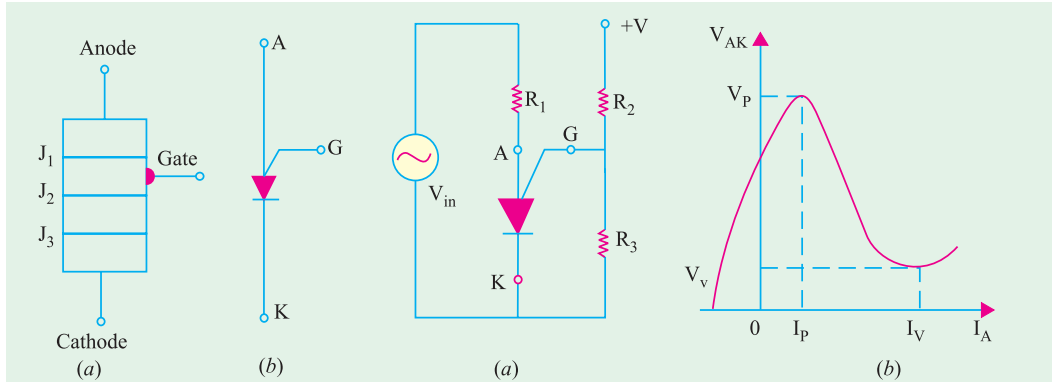

Fig. 64.7

Fig. 64.8

Fig. 64.8 (b) shows the plot of anode-to-cathode voltage V_{AK} versus anode current I_A . It is similar to the V/I characteristic of a UJT . Hence, PUT replaces UJT in many applications, one such application is as relaxation oscillator shown in Fig. 64.9 (a).

Since, $R_2 = R_3$, $V_G = 12 / 2 = 6 \text{ V}$. When dc voltage is applied, the PUT is off but C starts charging towards $+12 \text{ V}$ through R_1 [Fig. 64.9 (b)]. When V_C exceeds $(V_G + 0.7 \text{ V})$, the PUT turns ON and, at the same time, C starts discharging rapidly through the low ON-resistance of the PUT and R_4 . Consequently, a voltage spike is developed across R_4 during the discharge. As soon as C discharges, the PUT turns OFF and the charging cycle starts all over again as described above.



Silicon controlled rectifier and power diode

64.5. Silicon Controlled Rectifier

It is one of the prominent members of the thyristor family. It is a four-layer or PNPN device. Basically, *it is a rectifier with a control element*. In fact, it consists of *three diodes* connected back-to-back with a gate connection. It is widely used as a switching device in power control applications. It can control loads by switching current OFF and ON up to many thousand times a second. It can switch ON for variable lengths of time, thereby delivering selected amount of power to the load. Hence, it possesses the advantages of a rheostat and a switch with none of their disadvantages.

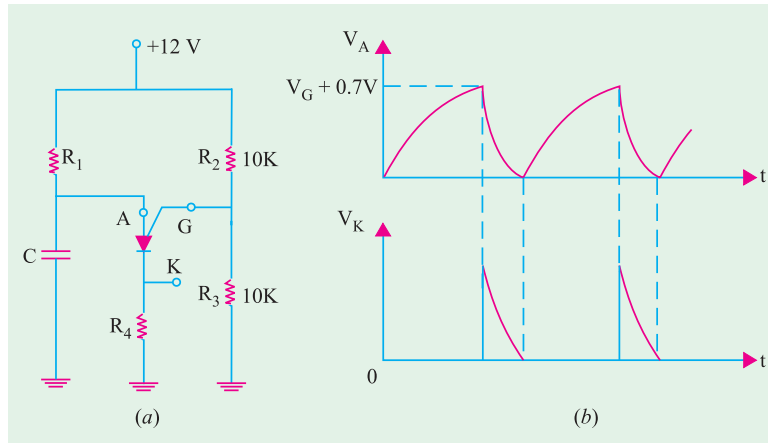

Fig. 64.9

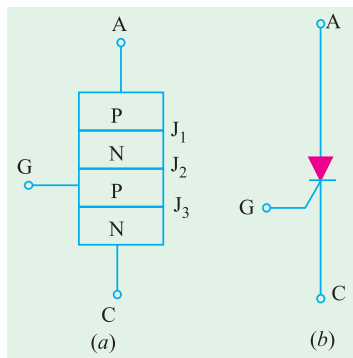

Fig. 64.10

(a) Construction

As shown in Fig. 64.10 (a), it is a three terminal four-layer transistor, the layers being alternately of P-type and N-type silicon. The three junctions are marked J₁, J₂ and J₃ whereas the three terminals are : anode (A), cathode (C) and gate (G) which is connected to the *inner P-type* layer. The function of the gate is to control the firing of SCR. The schematic symbol is shown in Fig. 64.10 (b).

Since, they conduct large currents, junction areas of SCRs are very large. Commonly used stud-mounted units have their anode connected directly to the stud for good heat dissipation whereas larger units are of ‘pillow’ type in which many units are stacked in series and held in a pressurized clamp.

(b) Biasing

With the polarity of V as shown in Fig. 64.11 (a), the junctions J₁ and J₃ become forward-biased whereas J₂ is reverse-biased. Hence, no current (except leakage current) can flow through the SCR.

In Fig. 64.11 (b), polarity of V has been reversed. It is seen that, now, junctions J₁ and J₃ become reverse-biased and only J₂ is forward-biased. Again, there is no flow of current through the SCR.

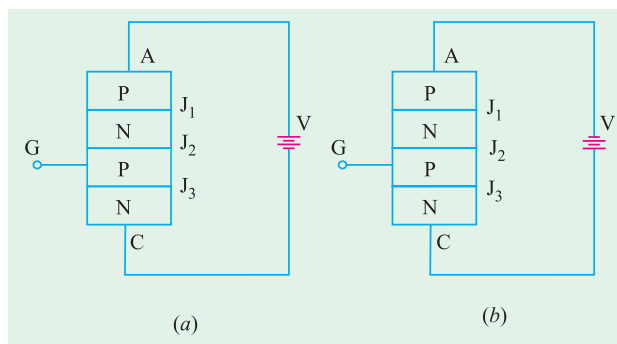

Fig. 64.11

(c) Operation

In Fig. 64.11 (a), current flow is blocked due to reverse-biased junction J₂. However, when anode voltage is increased, a certain critical value called forward breakover voltage V_{BO} is reached when J₂ breaks down and SCR switches suddenly to a highly conducting state. Under this condition,

SCR offers very little forward resistance ($0.01 \Omega - 1.0 \Omega$) so that voltage across it drops to a low value (about 1 V) as shown in Fig. 64.12 and current is limited only by the power supply and the load resistance. Current keeps flowing indefinitely until the circuit is opened briefly.

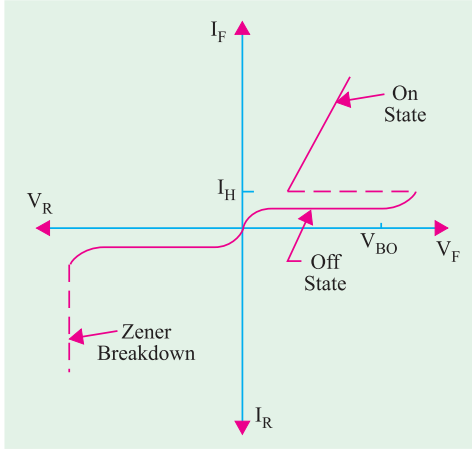

Fig. 64.12

With supply connection as in Fig. 64.11 (b), the current through the SCR is blocked by the two reverse-biased junctions J_1 and J_3 . When V is increased, a stage comes when Zener breakdown occurs which may destroy the SCR (Fig. 64.12). Hence, it is seen that SCR is a unidirectional device unlike triac *which is bi-directional*.

(d) Two Transistor Analogy

The basic operation of a SCR can be described by using two transistor analogy. For this purpose, SCR is split into two 3-layer transistor structures as shown in Fig. 64.13 (a). As seen, transistor Q_1 is a PNP transistor whereas Q_2 is an NPN device interconnected together. It will also be noted from Fig. 64.13 (b) that

- (i) collector current of Q_1 is also the base current of Q_2 and
- (ii) base current of Q_1 is also the collector current of Q_2 .

Suppose that the supply voltage across terminals A and C is such that reverse-biased junction J_2 starts breaking down. Then, current through the device begins to rise. It means that I_{E1} begins to increase.

Then,

1. I_{C1} increases (remember $I_C = \alpha I_E$);
2. since $I_{C1} = I_{B2}$, I_{B2} also increases;
3. hence, I_{C2} increases (remember $I_C = \beta I_B$);
4. now, $I_{C2} = I_{B1}$, hence I_{B1} increases;
5. consequently, both I_{C1} and I_{E1} increase.

As seen, a regenerative action takes place whereby an initial increase in current produces further increase in the same current. Soon, maximum current is reached limited by external resistances. The two transistors are fully turned ON and voltage across the two transistors falls to a very low value. Typical turn-ON times for an SCR are 0.1 to 1.0 μs .

It can be proved that if I_G is the gate current of the SCR and α_1 and α_2 , the current gains of the PNP and NPN transistors respectively, then anode current is given by

$$I_A = \frac{\alpha_2 I_G}{1 - (\alpha_1 + \alpha_2)}$$

(e) Firing and Triggering

Usually, SCR is operated with an anode voltage *slightly less* than the forward breakover voltage V_{BO} and is triggered into conduction by a low-power gate pulse. Once switched ON, gate has no further control on the device current. Gate signals can be (a) dc firing signals [Fig. 64.14 (a)] or (b) pulse signals [Fig. 64.14 (b)].

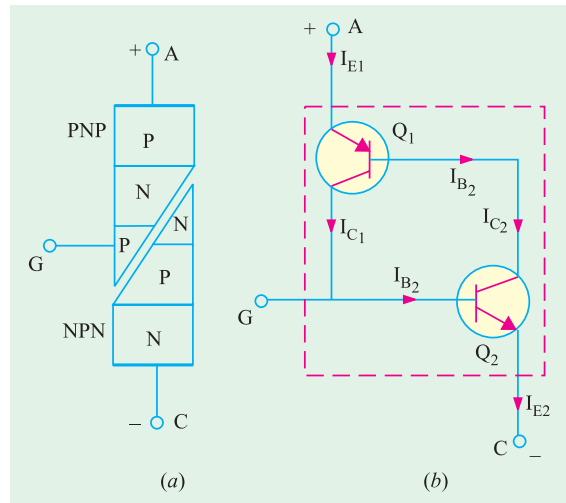

Fig. 64.13

In Fig. 64.14 (a) with S open, SCR does not conduct and the lamp is out. When S is closed momentarily, a positive voltage is applied to the gate which forward-biases the centre P - N junction.

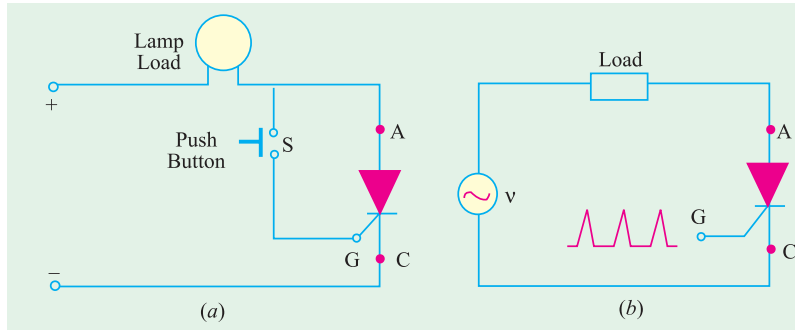

Fig. 64.14

As a result, SCR is pulsed into conduction and the lamp lights up. SCR will remain in the conducting state until the supply voltage is removed or reversed. Fig. 64.14 (b) shows triggering by timed pulses obtained from a pulse source.

We have discussed above the most common method of SCR triggering *i.e.* gate triggering. However, other available triggering methods are as under :

1. Thermal Triggering

In this case, the temperature of the forward-biased junction is increased till the reverse-biased junction breaks down.

2. Radiation Triggering

Here, triggering is achieved with the help of charge carriers which are produced by the bombardment of the SCR with external high-energy particles like neutrons or protons.

3. Voltage Triggering

In this case, the voltage applied across the anode and cathode of the SCR is increased which decreases the width of the depletion layer at the reverse-biased junction leading to its collapse.

4. dv/dt Triggering

In this case, dv/dt is made more than the value of the critical rate of rise of the voltage.

(f) Turning OFF

As stated earlier, once 'fired', SCR remains ON *even when triggering pulse is removed*. This ability of the SCR to remain ON even when gate current is removed is referred to as **latching**. In fact, SCR belongs to a class of devices known as **latching devices**.

By now, it is clear that an SCR cannot be turned OFF by simply removing the gate pulse. Number of techniques are employed to turn an SCR off. These are :

1. anode current interruption.
2. reversing polarity of anode-cathode voltage as is done each half-cycle by v in Fig. 64.14 (b);
3. reducing current through SCR below the holding current I_H (Fig. 64.12). It is also called **low-current dropout**.

(g) Applications

Main application of an SCR is as a **power control device**. It has been shown above that when SCR is OFF, its current is negligible and when it is ON, its voltage is negligible. Consequently, it never dissipates any appreciable amount of power even when controlling substantial amounts of load power. For example, one SCR requires only 150 mA to control a load current of 2500 A. Other common areas of its application include.

- | | | |
|---------------------|------------------------------|----------------------|
| 1. relay controls, | 2. regulated power supplies, | 3. static switches, |
| 4. motor controls, | 5. inverters, | 6. battery chargers, |
| 7. heater controls, | 8. phase control. | |

SCRs have been designed to control powers upto 10 MW with individual ratings as high as 2000 A at 1.8 kV. Its frequency range of application has been extended to about 50 kHz.

Example 64.4. The two-transistor analogy of an SCR has the following data :
 gain of PNP transistor = 0.4 ; gain of NPN transistor = 0.5 ;
 gate current = 50 mA.

Calculate the anode current of the device.

Solution. Here, $\alpha_1 = 0.4$; $\alpha_2 = 0.5$ and $I_G = 50 \text{ mA} = 0.05 \text{ A}$

$$\text{anode current, } I_A = \frac{\alpha_2 I_G}{1 - (\alpha_1 + \alpha_2)} = \frac{0.5 \times 0.05}{1 - (0.4 + 0.5)} = 0.25 \text{ A} = \mathbf{250 \text{ mA}}$$

64.6. Comparison Between Transistors and Thyristors

Table No. 64.1 gives the comparison between transistors and thyristors.

Table No. 64.1		
Sl.No.	Transistors	Thyristors
1.	3-layers, 2-junction devices	4-layer, 2- or more junction devices
2.	fast response	very fast response
3.	high efficiency	very high efficiency
4.	highly reliable	very highly reliable
5.	small voltage drop	very small voltage drop
6.	long life	very long life
7.	small to medium power ratings	very small to very large power ratings
8.	require a continuous flow of current to remain in conducting state	require only a small pulse for triggering and thereafter remaining in conducting state.
9.	low power consumption	very low power consumption
10.	low control capability	high control capability
11.	small turn-ON and turn-OFF time	very small turn-ON and turn-OFF time

Example 64.5. A 250 Ω resistor is connected in series with the gate of an SCR as shown in Fig. 64.15. The gate current required for firing the SCR is 8 mA. Calculate the value of the input voltage V_{in} required for causing the SCR to break down.

(Basic Electronics, Osmania Univ. 1993)

Solution. The value of V_{in} should be such as to (i) overcome the barrier voltage of 0.7 V and (ii) cause 8 mA current to flow through 250 Ω resistor.

$$V_{in} = V_{GC} + I_G R = 0.7 + 8 \times 10^{-3} \times 250 = \mathbf{2.7 \text{ V}}$$

64.7. Transient Effects in an SCR

We will consider the following two effects :

(i) di/dt Effect

This effect is produced due to a high initial rate-of-rise of the anode current when an SCR is just switched ON and results in the formation of a **local hot spot near the gate connection** as explained below :

When a triggering pulse is applied to the gate of an SCR, the holes are injected into the P-region where they crowd together and form an initial conduction zone over a small part of the junction J_2 before spreading the conduct throughout the whole area of junction. If the anode current is allowed to rise very rapidly (as would be the case for resistive or capacitive loads), this high current will be forced to flow through this small conduction zone until the conduction has spread through the entire junction. This may result in local hot-spots in the junction which are likely to damage the SCR permanently.

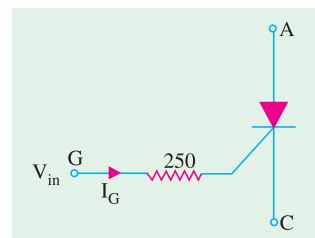

Fig. 64.15

The maximum allowable anode current di/dt can be increased (and, hence, turn-on time of an SCR decreased) by using specially-designed gate-connection geometries which result in a more rapid distribution of charge throughout the gate region.

(ii) dv/dt Effect

It is found that sometimes an SCR unwantedly turns ON by itself during sudden changes of the applied anode potential at a time when there is no gate current applied and the SCR is supposed to be blocking. This false triggering is due to the capacitance possessed by the large-area junction J_2 (Fig. 64.10). When rate-of-rise of the applied anode voltage dv/dt is very high, the capacitive charging current may become high enough to initiate switch-on even in the absence of external gate current. False triggerings due to the dv/dt are prevented by using a ‘snubber circuit’.

64.8. Phase Control

In the phase control circuit of Fig. 64.16, gate triggering current is derived from the supply itself. The variable resistance R limits the gate current during positive half-cycles of the supply. If R is adjusted to a low value, SCR will trigger almost immediately at the commencement of the positive half-cycle of the input.

If, on the other hand, R is set to a high resistance, SCR may not switch ON until the peak of the positive half-cycle. By adjusting R between these two extremes, SCR can be

made to switch ON somewhere between the commencement and peak of the positive half-cycle *i.e.* between 0° and 90° .

It is obvious that if I_G is not enough to trigger the SCR at 90° , then the device will not trigger at all because I_G has maximum value then. This operation is sometimes referred to as *half-wave variable-resistance phase control*. It is an effective method of controlling the load power.

The purpose of diode D is to protect the gate from negative voltage which would otherwise be applied to it during the negative half-cycle of the input.

It is seen from Fig. 64.16 that at the instant of SCR switch-ON, gate current flows through R_L , R and D . Hence, at that *instant*

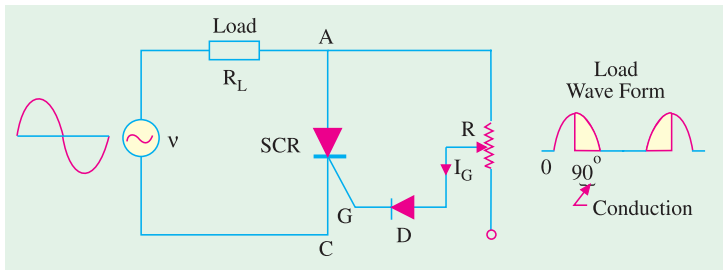

Fig. 64.16

$$v = I_G R_L + I_G R + V_D + V_G \quad \therefore R = \frac{v - V_D - V_G - I_G R_L}{I_G}$$

Example 64.6. The circuit of Fig. 64.16 is connected to an ac supply $v = 50 \sin \theta$ and $R_L = 50 \Omega$. Gate current is $100 \mu A$ and $V_G = 0.5 V$. Determine the range of adjustment of R for the SCR to be triggered between 30° and 90° . Take $V_D = 0.7 V$.

Solution. (i)

$\theta = 30^\circ$

Now, $v = 50 \sin \theta = 50 \sin 30^\circ = 25 V$

$\therefore R = \frac{25 - 0.7 - 0.5 - (100 \times 10^{-6} \times 50)}{100 \times 10^{-6}} = 238K$

(ii)

$\theta = 90^\circ$

$v = 50 \sin 90^\circ = 50 V$

$R = \frac{50 - 0.7 - 0.5 - 0.005}{100 \times 10^{-6}} = 488K$

64.9. Theft Alarm

The circuit shown in Fig. 64.17 can be used to protect a car tape deck or a radio receiver from theft. The switch S is located at some concealed point in the car and is kept *closed*. Since gate G is grounded through the tape deck, the SCR is OFF and the horn is silent. If the tape deck is removed, G is no longer grounded. Instead, it gets connected to the car battery through R . Consequently, gate current is set up which fires the SCR. As a result, the horn starts blowing and continues to do so until S is opened.

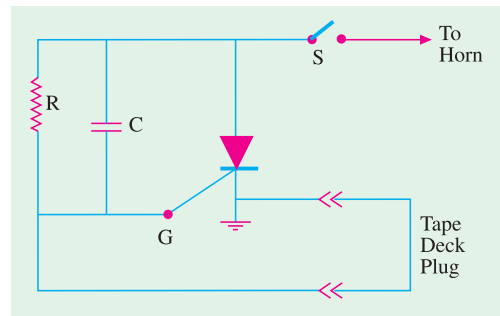

Fig. 64.17

64.10. Emergency Lighting System

SCRs find application in circuits that maintain lighting by using a backup battery in case of ac power failure. Fig. 64.18 shows a centre-tapped full-wave rectifier used for providing power to a low-voltage lamp. So long as ac power is available, the battery is charged *via* diode D_3 and resistor R_1 [Fig. 64.18 (a)].

With ac power ON, the capacitor C charges to the peak value of the full-wave rectified ac voltage *i.e.* to $12.4 \times 1.414 = 17.5$ V. Same is the voltage of the SCR cathode K .

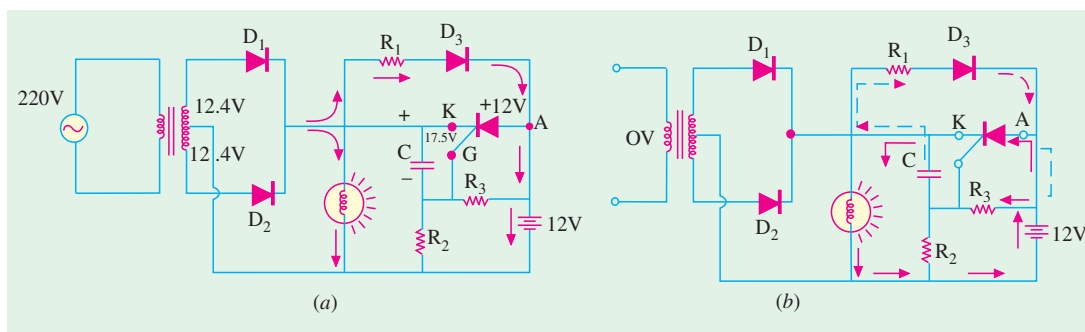

Fig. 64.18

Since voltage of SCR anode A is less than that of K , the SCR does not conduct. The SCR gate G is at a voltage determined by voltage divider R_3 - R_2 . Under these conditions, the lamp is run by the ac supply and SCR is OFF.

When ac power is interrupted :

- (i) the capacitor C discharges through the closed path R_1 , D_3 and R_3 shown by dotted arrows;
- (ii) the cathode voltage decreases thereby making it less positive than anode;
- (iii) this triggers SCR into conduction which allows the battery current to pass through the lamp thus maintaining illumination.

When ac supply is restored, C recharges and the SCR turns OFF. The battery starts recharging again.

64.11. Light Activated SCR (LASCR)

It is just an ordinary SCR except that *it can also be light-triggered*. Most LASCRs also have a gate terminal for being triggered by an electrical pulse just as a conventional SCR. Fig. 64.19 shows the two LASCR symbols used commonly.

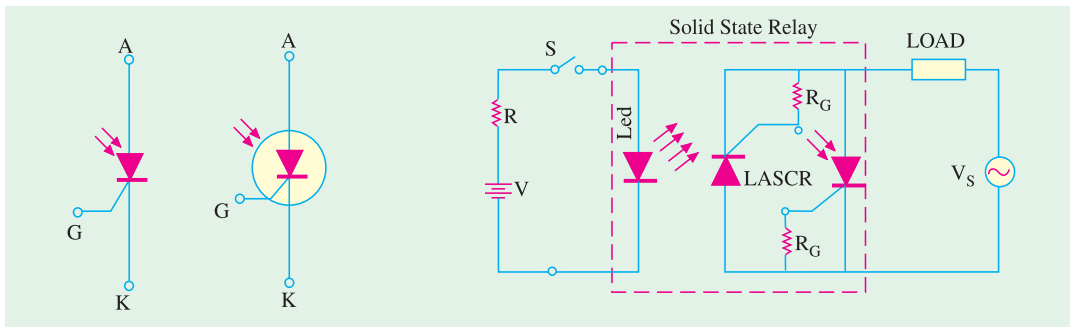

Fig. 64.19

Fig. 64.20

LASCs are manufactured mostly in relatively low-current ranges and are used for triggering larger SCRs and triacs. They are used in optical light controls, relays, motor control and a variety of computer applications. Some LASCs have clear windows in their cases so that light sources from other devices can be coupled to them. Many have the light source device encapsulated in the same package so that a relay is formed. Since the relay action does not require direct electrical connection, such relays are often used to couple signals into very high voltage equipment and other dangerous locations. Fig. 64.20 shows the connection of such a solid-state relay. Two LASCs are connected in reverse parallel in order to obtain conduction in both half-cycles of the applied ac voltage V_s . A single LED is used to trigger both LASCs. Bias resistors are used to reduce the light sensitivity of the gates and prevent sporadic triggering during off-periods. Usually, all the three active devices and the two bias resistors R_G are encapsulated in the same package.

64.12. The Shockley Diode*

It is a *two-terminal four-layer* or *PNPN* device as shown in Fig. 64.21 along with its schematic symbol. It is essentially a low-current *SCR without a gate*. For switching the diode ON, its anode-to-cathode voltage (V_{AK}) must be increased to forward switching voltage (V_S) which is the equivalent of SCR forward breakover voltage. Like an SCR, it also has a holding current. The *PNPN* structure can be represented by an equivalent circuit consisting of a *PNP* transistor and an *NPN* transistor. One application of the diode is as a relaxation oscillator.

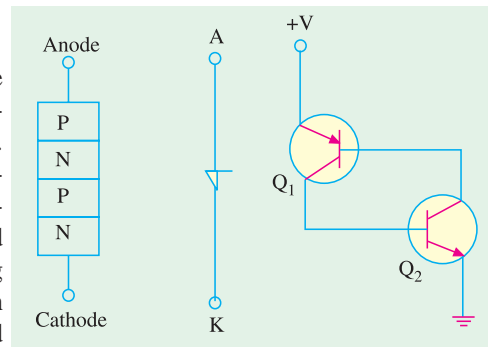

Fvsvg. 64.21

64.13. Triac

It is a *5-layer bi-directional device* which can be triggered into conduction by both *positive* and *negative* voltages at its anodes and with both *positive and negative* triggering pulses at its gate. It behaves like two SCRs *connected in parallel, upside down with respect to each other*. That is, the anode of one is tied to the cathode of the other and their gates are directly tied together. Hence, anode and gate voltages applied in either direction will fire a triac because they would fire at least one of the two SCRs which are in opposite directions.

Since a triac responds to both positive and negative voltages at the anode, the concept of cathode used for an SCR is dropped. Instead, the two electrodes are called anodes A_1 and A_2 .

* After the name of its inventor William Shockley.

1. Construction

As shown in Fig. 64.22 (a), a triac has three terminals A_1 , A_2 and G . As seen, gate G is closer to anode A_1 . It is clear from Fig. 64.22 (b), that a triac is nothing but **two inverse parallel-connected**

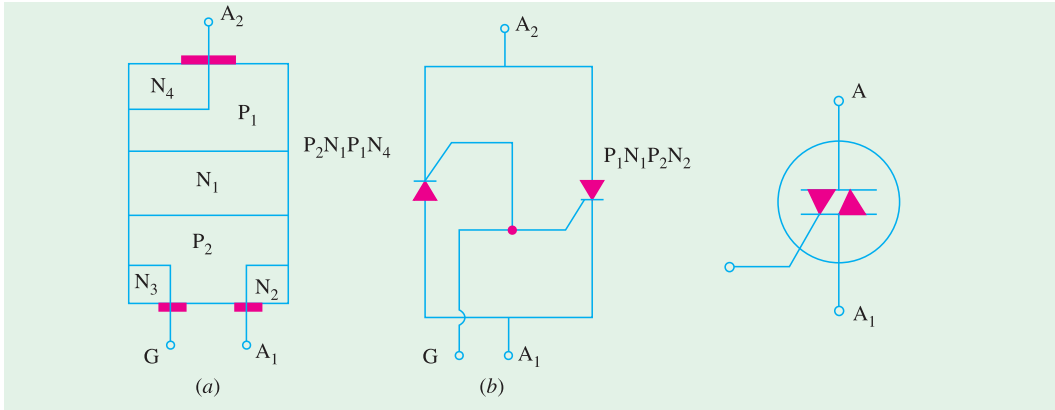

Fig. 64.22

Fig. 64.23

SCRs with a **common gate terminal**. As seen, it has six doped regions. Fig. 64.23 shows the schematic symbol which consists of two inverse-connected SCR symbols.

2. Operation

(a) When A_2 is Positive

When positive voltage is applied to A_2 , path of current flow is $P_1-N_1-P_2-N_2$. The two junctions P_1-N_1 and P_2-N_2 are forward-biased whereas N_1-P_2 junction is blocked. The gate can be given either positive or negative voltage to turn ON the triac as explained below.

(i) positive gate

A positive gate (with respect to A_1) forward-biases the P_2-N_2 junction and the breakdown occurs as in a normal SCR.

(ii) negative gate

A negative gate forward-biases the P_2-N_3 junction and current carriers injected into P_2 turn on the triac.

(b) When A_1 is Positive

When positive voltage is applied to anode A_1 , path of current flow is $P_2-N_1-P_1-N_4$. The two junctions P_2-N_1 and P_1-N_4 are forward-biased whereas junction N_1-P_1 is blocked. Conduction can be achieved by giving either positive or negative voltage to G as explained below.

(i) positive gate

A positive gate (with respect to A_1) injects current carriers by forward-biasing P_2-N_2 junction and thus initiates conduction.

(ii) negative gate

A negative gate injects current carriers by forward-biasing P_2-N_3 junction thereby triggering conduction.

It is seen that there are four triac-triggering modes, two each for the two anodes.

Low-current dropout is the only way to open a triac.

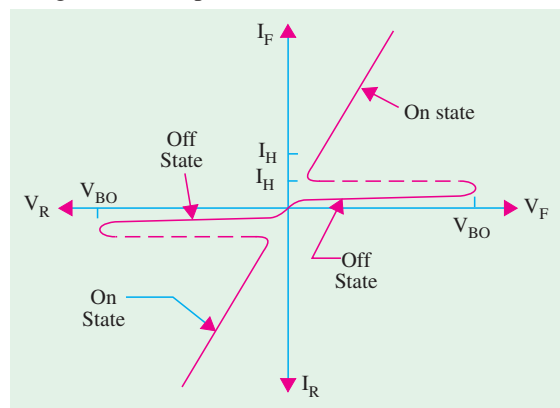

Fig. 64.24

3. V/I Characteristics

Typical characteristics of a triac are shown in Fig. 64.24.

As seen, triac exhibits same forward blocking and forward conducting characteristics as an SCR but for *either polarity of voltage applied to the main terminal*. Obviously, a triac has latch current in either direction.

4. Applications

One fundamental application of triac is shown in Fig. 64.25. Here, it is used to control ac power to a load by switching ON and OFF during positive and negative half-cycles of the input ac power.

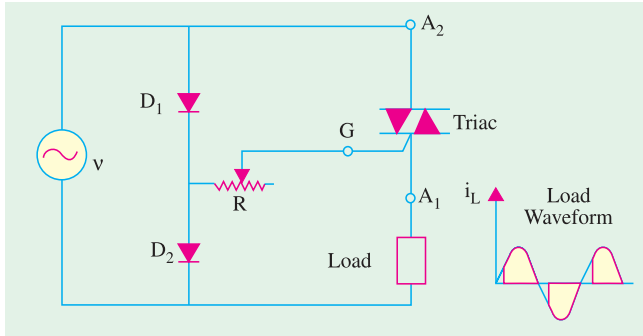

Fig. 64.25

During positive half-cycle of the input, diode D_1 is forward biased, D_2 is reverse-biased and gate is positive with respect to A_1 . By adjusting R , the point at which conduction commences can be varied.

Diac-triac combination for ac load power control is shown in Fig. 64.26. Firing control of diac is achieved by adjusting R .

Other applications of a triac include.

1. as static switch to turn ac power OFF and ON;
2. for minimizing radio interference;
3. for light control;
4. for motor speed control etc.

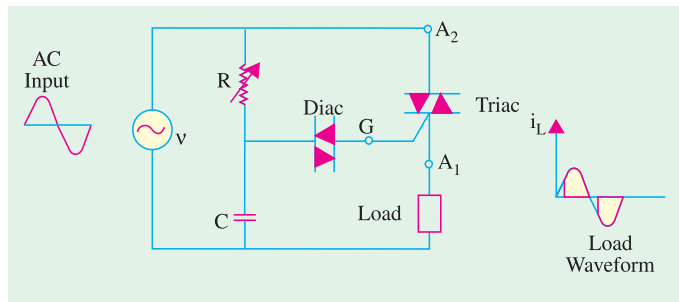

Fig. 64.26

The only disadvantage of triac is that it takes comparatively longer time to recover to OFF state. Hence, its use is limited to ac supply frequencies of upto 400 Hz.

64.14. Diac

To put it simply, a diac is nothing else but a *triac without its gate terminal* as shown in Fig.

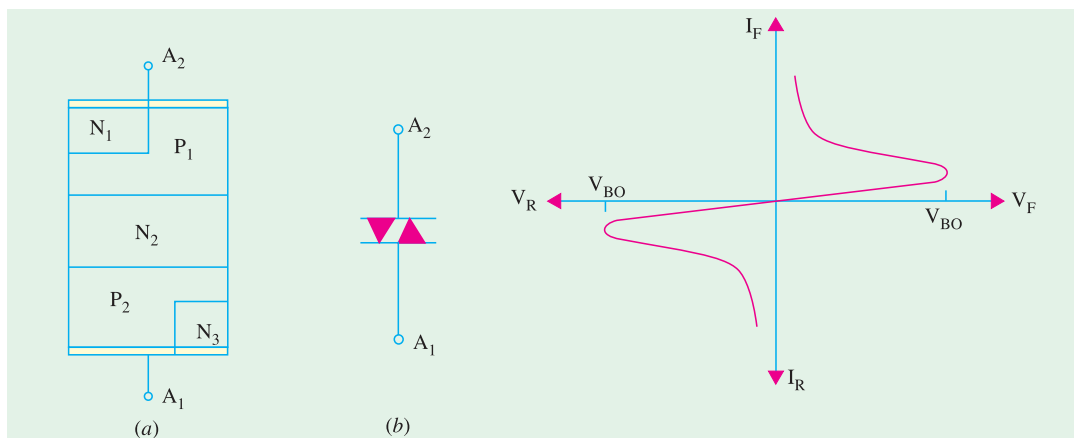

Fig. 64.27

Fig. 64.28

64.27 (a). Its equivalent circuit is a pair of inverted four layer diodes. Its schematic symbol is shown in Fig. 64.27 (b). As seen, **it can break down in either direction.**

When anode A_1 is positive, the current path is $P_2-N_2-P_1-N_1$. Similarly, when A_2 is positive, the current flow path is $P_1-N_2-P_2-N_3$. Diac is designed to trigger triacs or provide protection against over-voltages.

The operation of a diac can best be explained by imaging it as **two-diodes connected in series**. Voltage applied across it in either direction turns ON one diode, reverse-biasing the other. Hence, it can be switched from OFF to ON state for either polarity of the applied voltage.

The characteristic curve of a typical diac is shown in Fig. 64.28. It resembles the letter Z since diac breaks down in either direction.

As stated above, diac has symmetrical bi-directional switching characteristics. Because of this feature, diacs are frequently used as triggering devices in triac phase control circuits used for light dimming, universal motor speed control and heat control etc.

64.15. Silicon Controlled Switch (SCS)

It is a four-layer, four-terminal *PNPN* device having anode A , cathode C , anode gate G_1 and cathode gate G_2 as shown in Fig. 64.29. In fact, **it is a low-current SCR with two gate terminals**. The two transistor equivalent circuit is shown in Fig. 64.30.

Switching ON and OFF

The device may be switched ON or OFF by a suitable pulse is applied at either gate. As seen from Fig. 64.30, a negative pulse is required at anode gate G_1 to turn the device ON whereas positive pulse is needed to turn it OFF as explained below.

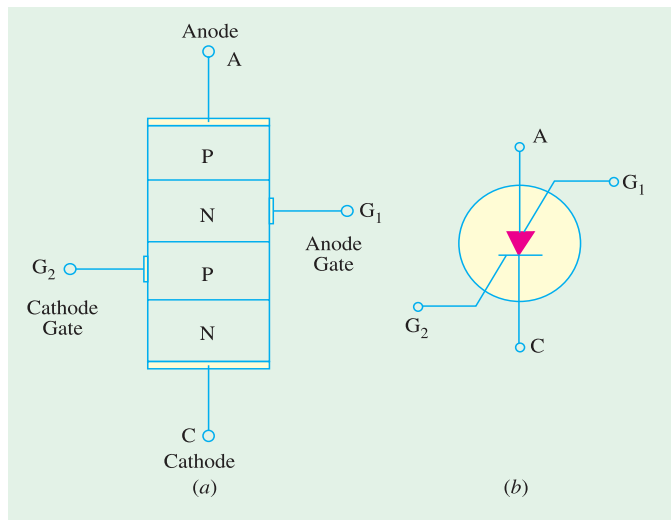

Fig. 64.29

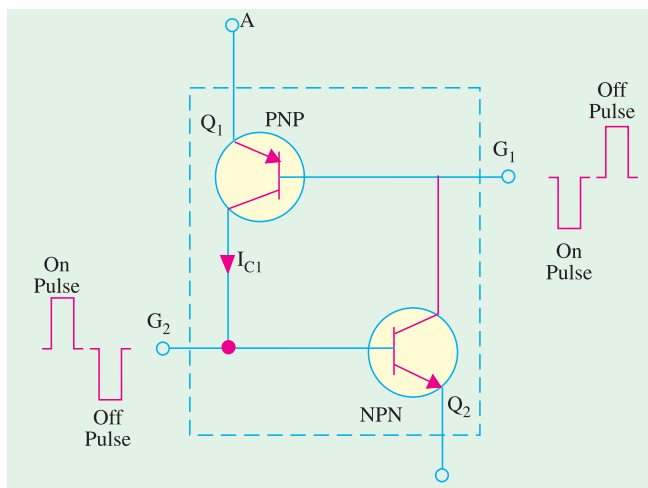

Fig. 64.30

Similarly, at cathode gate G_2 , a negative pulse is required to switch the device OFF and a positive pulse to turn it ON.

As seen from Fig. 64.30, when a negative pulse is applied to G_1 , it forward-biases Q_1 (being *PNP*) which is turned ON. The resulting heavy collector current I_C , being the base current of Q_2 , turns it ON. Hence, SCS is switched ON. A positive pulse at G_1 will reverse bias E/B junction of Q_1 thereby switching the SCS OFF.

V/I Characteristics

The V/I characteristics of an SCS are essentially the same **as those for the SCR** (Fig. 64.13).

As compared to an SCR, an SCS has *much reduced turn-OFF time*. Moreover, it has higher control and triggering sensitivity and a more predictable firing situation.

Applications

The more common areas of SCS applications are as under :

1. in counters, registers and timing circuits of computers,
2. pulse generators,
3. voltage sensors,
4. oscillators etc.

OBJECTIVE TESTS – 64

1. A unijunction transistor has
 - (a) anode, cathode and a gate
 - (b) two bases and one emitter
 - (c) two anodes and one gate
 - (d) anode, cathode and two gates.
2. Which semiconductor device acts like a diode and two resistors ?
 - (a) SCR
 - (b) triac
 - (c) diac
 - (d) UJT.
3. A UJT has $R_{BB} = 10\text{ K}$ and $R_{B2} = 4\text{ K}$. Its intrinsic stand-off ratio is
 - (a) 0.6
 - (b) 0.4
 - (c) 2.5
 - (d) 5/3.
4. An SCR conducts appreciable current when its with respect to cathode.
 - (a) anode and gate are both negative
 - (b) anode and gate are both positive
 - (c) anode is negative and gate is positive
 - (d) gate is negative and anode is positive.
5. After firing an SCR, the gating pulse is removed. The current in the SCR will
 - (a) remains the same
 - (b) immediately fall to zero
 - (c) rise up
 - (d) rise a little and then fall to zero.
6. An SCR may be turned OFF by
 - (a) interrupting its anode current
 - (b) reversing polarity of its anode- cathode voltage
 - (c) low-current dropout
 - (d) all of the above.
7. A triac behaves like two
 - (a) inverse parallel-connected SCRs with common gate
 - (b) diodes in series
 - (c) four-layer diodes in parallel
 - (d) resistors and one diode.
8. A triac can be triggered into conduction by
 - (a) only positive voltage at either anode
 - (b) positive or negative voltage at either anode
 - (c) positive or negative voltage at gate
 - (d) both (b) and (c).
9. A diac is equivalent to a
 - (a) pair of SCRs
 - (b) pair of four-layer SCRs
 - (c) diode and two resistors
 - (d) triac with two gates.
10. An SCS has
 - (a) four layers and three terminals
 - (b) three layers and four terminals
 - (c) two anodes and two gates
 - (d) one anode, one cathode and two gates.
11. An SCS may be switched ON by a
 - (a) positive pulse at its anode
 - (b) negative pulse at its cathode
 - (c) positive pulse at its cathode gate G_2
 - (d) positive pulse at its anode gate G_1 .
12. The dv/dt effect in an SCR can result in
 - (a) high rate-of-rise of anode voltage
 - (b) increased junction capacitance
 - (c) false triggering
 - (d) low capacitive charging current.
13. The di/dt effect in an SCR leads to the formation of
 - (a) local hot spots
 - (b) conduction zone
 - (c) charge spreading zone
 - (d) none of the above.
14. SCR turns OFF from conducting state to blocking state on
 - (a) reducing gate current
 - (b) reversing gate voltage
 - (c) reducing anode current below holding current value
 - (d) applying ac to the gate
15. When a thyristor is negatively biased,
 - (a) all the three junctions are negatively biased
 - (b) outer junctions are positively biased and the inner junction is negatively biased.

- (c) outer junctions are negatively biased and the inner junction is positively biased
 - (d) the junction near the anode is negatively biased and the one near the cathode is positively biased.
- 16.** A LASCR is just like a conventional SCR except that it
- (a) cannot carry large current
 - (b) can also be light-triggered
 - (c) has no gate terminal
 - (d) cannot be pulse-triggered.
- 17.** The minimum value of current required to maintain conduction in an SCR is called its current.
- (a) commutation
 - (b) holding
 - (c) gate trigger
 - (d) breakover
- 18.** Diacs are primarily used as
- (a) pulse generators
 - (b) triggering devices
 - (c) surge protection devices
 - (d) power thyristors.

ANSWERS

- 1.** (b) **2.** (d) **3.** (a) **4.** (b) **5.** (a) **6.** (d) **7.** (a) **8.** (d) **9.** (b) **10.** (d) **11.** (c)
12. (c) **13.** (a) **14.** (c) **15.** (c) **16.** (b) **17.** (b) **18.** (b)