

C H A P T E R 55

Learning Objectives

- Unregulated Power Supply
- Regulated Power Supply
- Rectifiers
- Single-phase Half-wave Rectifier
- Six-phase Half-wave Rectifier
- Filters
- Shunt Capacitor Filter
- Effect of increasing Filter Capacitance
- Series Inductor Filter
- The Choke Input of L-C Filter
- The R-C Filter
- The C-L-C or Pi Filter
- Bleeder Resistor
- Voltage Dividers
- Complete Power Supply
- Voltage Multipliers
- Half-wave Voltage Doubler
- Full-wave Voltage Doubler
- Voltage Tripler and Quadrupler Circuits
- Troubleshooting Power Supplies
- Controlled Rectification
- Output Voltage and Current Values in Controlled Rectifiers
- Average Values for FW Controlled Rectifier
- Silicon Controlled Rectifier
- 180° Phase Control of SCR
- SCR Controlled Load Circuit
- UJT Controlled Load Circuit
- Chopper
- Inverters
- Single Phase Inverter
- Push-pull Inverter

DC POWER SUPPLIES



↑ Low cost DC Power Supply



5. Voltage Divider: Its function is to provide different dc-voltages needed by different electronic circuits. It consists of a number of resistors connected in series across the output terminals of the voltage regulator. Obviously, it eliminates the necessity of providing separate dc power supplies to different electronic circuits working on different dc levels.

Comments. Strictly speaking, all that is really required for conversion from ac to dc is a transformer and a rectifier (in fact, even the transformer could be eliminated if no voltage transformation is required). The filter, voltage regulator and voltage divider are mere refinements of a dc power supply though they are essential for most applications except for battery charging and running small dc motors etc.

55.4. Rectifiers

We will consider the following circuits :

- | | |
|--------------------------------------|--------------------------------------|
| 1. single-phase half-wave rectifier, | 2. single-phase full-wave rectifier, |
| 3. full-wave bridge circuit, | 4. three-phase half-wave rectifier, |
| 5. three-phase full-wave rectifier, | 6. six-phase half-wave rectifier, |
| 7. three-phase bridge circuit, | 8. voltage multiplier circuits. |

Many semiconductor devices or systems (like car stereo systems) require a negative dc source or both a negative and a positive dc source. For the sake of simplicity, we will analyse only the positive dc power supplies. However, a positive dc supply can be converted into a negative one by simply reversing the two leads in the same way as we reverse the polarity of a dry cell.

Quite a number of integrated circuits (ICs) require both positive and negative source with common ground. In that case, the polarised components in the negative portion of the supply will have to be reversed. For example, its rectifier, filter capacitor and voltage/current regulation devices will have to be reversed as compared to the positive supply.

55.5. Single-phase Half-Wave Rectifier

The basic circuit of a half-wave rectifier with a resistive load (but no filter circuit) is shown in Fig. 55.2 (a). The alternating secondary voltage is applied to a diode connected in series with a load resistor R_L . Let the equation of the alternating secondary voltage be $V_s = V_{sm} \sin \omega t$.

(a) Working

During the positive half-cycle of the input ac voltage, the diode D is forward-biased (ON) and conducts. While conducting, the diode acts as a short-circuit so that circuit current flows and hence, positive half-cycle of the input ac voltage is dropped across R_L . It constitutes the output voltage V_L as shown in Fig. 55.2 (b). Waveform of the load voltage is also shown in Fig. 55.2 (b). It consists of half-wave rectified sinusoids of peak value V_{LM}

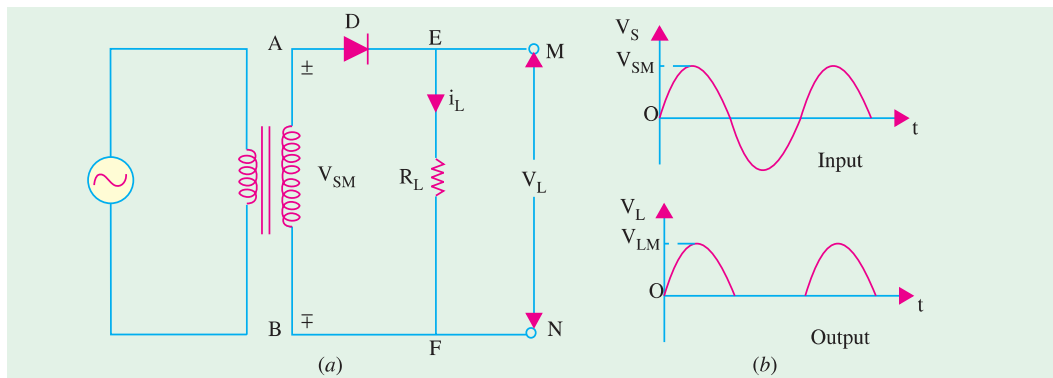

Fig. 55.2

During the negative input half-cycle, the diode is reverse-biased (OFF) and so, does not conduct *i.e.* there is no current flow. Hence, there is no voltage drop across R_L . In other words $i_L = 0$ and



$V_L = 0$. Obviously, the negative input half-cycle is suppressed *i.e.* it is not utilized for delivering power to the load. As seen, the output is not a steady dc but **only a pulsating dc wave** having a ripple frequency equal to that of the input voltage frequency. This wave can be observed by an oscilloscope connected across R_L . When measured by a dc meter, it will show some **average** positive value both for voltage and current. Since only one half-cycle of the input wave is used, it is called a half-wave rectifier. It should be noted that forward voltage drop across the diode has been neglected in the above discussion. We have, in fact, assumed an ideal diode (having zero forward resistance and infinite reverse resistance).

(b) Average and RMS Values

- Let
- V_{sm} = maximum value of transformer secondary voltage
 - V_s = rms value of secondary voltage
 - V_{LM} = maximum value of load voltage
= V_{sm} – diode drop – secondary resistance drop
 - V_L = rms value of load voltage
 - I_L = rms value of load current
 - $V_{L(dc)}$ = average value of load voltage
 - $I_{L(dc)}$ = average value of load current
 - I_{LM} = maximum value of load current
 - R_L = load resistance
 - R_S = transformer secondary resistance
 - r_d = diode forward resistance
 - $R_0 = R_S + r_d$
 - $I_{LM} = \frac{V_{sm} - V_B}{(R_S + r_d) + R_L} = \frac{V_{sm} - V_B}{R_0 + R_L}$, $V_{LM} = I_{LM} \cdot R_L$
 - $V_{L(dc)} = \frac{V_{LM}}{\pi} = 0.318 V_{LM}$, $I_{L(dc)} = \frac{I_{LM}}{\pi} = 0.318 I_{LM}$
 - $I_L = I_{LM} / \sqrt{2} = 0.5 I_{LM} = 0.5 V_{LM} / R_L$

(c) Efficiency

The efficiency of rectification is given by the ratio of the output dc power to the total amount of input power supplied to the circuit. It is also called the conversion efficiency.

$$\eta = \frac{P_{dc}}{P_{in}} = \frac{\text{power in the load}}{\text{input power}}$$

Now,

$$P_{dc} = I_{L(dc)}^2 R_L = \left(\frac{I_{LM}}{\pi}\right)^2 R_L = \frac{I_{LM}^2}{\pi^2} \cdot R_L$$

$$P_{in} = I_L^2 (R_L + R_0) = \left(\frac{I_{LM}}{2}\right)^2 (R_L + R_0) = \frac{I_{LM}^2}{4} (R_L + R_0)$$

$$\therefore \eta = \frac{P_{dc}}{P_{in}} = \left(\frac{4}{\pi^2}\right) \frac{R_L}{(R_L + R_0)} = \frac{0.406}{1 + R_0/R_L} = \frac{40.6\%}{(1 + R_0/R_L)}$$

If R_0 is neglected $\eta = 40.6\%$. Obviously, it is the maximum possible efficiency of a half-wave rectifier.

(d) Frequency Components of H.W. Rectified Voltage and Current

As shown in Fig. 55.3, the load current I_L consist of a dc component $I_{L(dc)}$ and an ac component $I_{L(ac)}$. The Fourier series of the half-wave rectified current flowing through the load is found to be

$$i_L = I_{LM} \left(\frac{1}{\pi} + \frac{1}{2} \sin \omega t - \frac{2}{3\pi} \cos 2\omega t - \frac{2}{15\pi} \cos 4\omega t + \dots \right)$$



As seen, the half-wave rectified current consists of a large number of ac components (which constitute the ripple) in addition to the dc component. The first term is I_{LM}/π which represents the dc component $I_{L(dc)}$. The second term $(I_{LM}/2) \sin \omega t$ has peak value of $(I_{LM}/2)$. It is called the fundamental or first harmonic component and its rms value is $I_{L1} = I_{LM}/2 \sqrt{2}$.

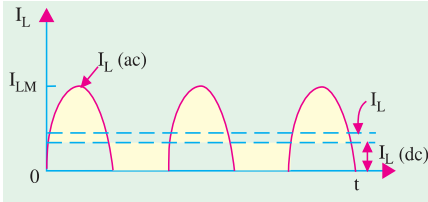

Fig. 55.3

The third term represents the second harmonic component whose frequency is double that of the supply frequency. The rms value is $I_{L2} = \text{peak value}/\sqrt{2} = 2 I_{LM}/3 \pi \sqrt{2} = I_{LM}/3\pi$.

The fourth term represents the third harmonic component whose frequency is four times the supply frequency. Its rms value is $2 I_{LM}/15 \pi \times \sqrt{2} = \sqrt{2} \cdot I_{LM}/15 \pi$.

The rms values of other components can be similarly calculated. However, they are found to be of continuously diminishing value.

As discussed above, the rectified output (or load) current consists of

- (i) dc component, $I_{L(dc)} = I_{LM}/\pi$ and
- (ii) ac components of rms values I_{L1}, I_{L2} and I_{L3} etc. Their combined rms value is given by

$$I_{L(ac)} = \sqrt{I_{L1}^2 + I_{L2}^2 + I_{L3}^2 + \dots}$$

The rms (or effective) value of the total load current is given by

$$I_L = \sqrt{I_{L(dc)}^2 + I_{L(ac)}^2} = \sqrt{I_{L(dc)}^2 + (I_{L1}^2 + I_{L2}^2 + I_{L3}^2 + \dots)}$$

Similarly, the Fourier series of the load voltage is given by

$$V_L = V_{LM} \left(\frac{1}{\pi} + \frac{1}{2} \sin \omega t - \frac{2}{3\pi} \cos 2 \omega t - \frac{2}{15 \pi} \cos 4 \omega t \dots \right)$$

It also consists of

- (i) a dc component, $V_{L(dc)} = V_{LM}/\pi$
- (ii) ac components of rms values V_{L1}, V_{L2} and V_{L3} etc. which are given by $V_{L1} = V_{LM}/\sqrt{2}, V_{L2} = \sqrt{2} \cdot V_{LM}/3 \pi; V_{L3} = \sqrt{2} V_{LM}/15 \pi$ etc.

Again, $V_{L(ac)} = \sqrt{V_{L1}^2 + V_{L2}^2 + V_{L3}^2 + \dots}$

The rms value of the entire load voltage is given by

$$V = \sqrt{V_{L(dc)}^2 + V_{L(ac)}^2} = \sqrt{V_{L(dc)}^2 + V_{L1}^2 + V_{L2}^2 + V_{L3}^2 + \dots}$$

(e) Ripple Factor

When defined in terms of voltage, it is given by

$$\gamma = \frac{\text{rms value of ac components}}{\text{dc value of load voltage}} = \frac{V_{L(ac)}}{V_{L(dc)}} = \frac{V_{r(ms)}}{V_{L(ms)}}$$

In terms of current, we have $\gamma = I_{L(ac)}/I_{L(dc)}$

As seen from above, $I_{L(ac)} = \sqrt{I_L^2 - I_{L(dc)}^2}$

$$\gamma = \frac{I_{L(ac)}}{I_{L(dc)}} = \frac{\sqrt{I_L^2 - I_{L(dc)}^2}}{I_{L(dc)}} = \sqrt{\left(\frac{I_L}{I_{dc}}\right)^2 - 1}$$

Now, $I_L/I_{L(dc)} = \text{form factor } K_f \text{ (Art 12.18)} \therefore \gamma = \sqrt{K_f^2 - 1}$

In the case of a half-wave rectifies with resistive load but no filter $K_f = \pi/2 = 1.57$

$\therefore \gamma = \sqrt{1.57^2 - 1} = 1.21$



Alternatively, the value of γ could be found as under :

If we neglect fourth and higher harmonics in the load current, then as seen from above

$$I_{L(ac)} = \sqrt{I_{L1}^2 + I_{L2}^2 + I_{L3}^2 + \dots}$$

$$= \sqrt{(I_{LM} / 2\sqrt{2})^2 + (\sqrt{2}I_{LM} / 3\pi)^2 + (\sqrt{2} \cdot I_{LM} / 15\pi)^2 + \dots} = 0.385 I_{LM}$$

$$\therefore \gamma = \frac{I_{L(ac)}}{I_{L(dc)}} = \frac{0.385 I_{LM}}{I_{LM} / \pi} = \frac{0.385 I_{LM}}{0.318 I_{LM}} = 1.21$$

(f) Peak Inverse Voltage (PIV)

It is the maximum voltage that occurs across the rectifying diode *in the reverse direction*. As seen from Fig. 55.2, the diode is reverse-biased during the negative half-cycle and the maximum voltage applied across it equals the maximum secondary voltage *i.e.* V_{sm} .

(g) Transformer Utilization Factor (TUF)

While designing any power supply, it is necessary to determine the rating of the transformer. It can be done provided *TUF* is known. The value of *TUF* depends on the amount of power to be delivered to the load and the type of rectifier circuit to be used.

$$TUF = \frac{\text{dc power delivered to the load}}{\text{ac rating of transformer secondary}}$$

$$= \frac{P_{dc}}{P_{ac.rated}} = \frac{P_{dc}}{P_{in.rated}}$$

At first sight it might appear as if the above ratio is the same as the conversion efficiency. Actually, it is not so because the rating of the transformer secondary is different from the actual power delivered by the secondary.

$$P_{dc} = V_{L(dc)} \cdot I_{L(dc)} = \frac{V_{LM}}{\pi} \cdot \frac{V_{LM}}{R_L} = \frac{V_{LM}^2}{\pi R_L}$$

$$= \frac{V_{sm}^2}{\pi R_L} \quad \text{—if drop over } R_0 \text{ is neglected}$$

Now, the rated voltage of transformer secondary is $V_{sm}/\sqrt{2}$ but the actual current flowing through the secondary is $I_L = I_{LM}/2$ (and not $I_{LM}/\sqrt{2}$) since it is a half-wave rectified current.

$$P_{ac.rated} = \frac{V_{sm}}{\sqrt{2}} \cdot \frac{I_{LM}}{2} = \frac{V_{sm}}{\sqrt{2}} \cdot \frac{V_{LM}}{2 R_L} = \frac{V_{sm}^2}{2\sqrt{2} R_L}$$

$$TUF = \frac{V_{sm}^2 / \pi R_L}{V_{sm}^2 / 2\sqrt{2} R_L} = \frac{2\sqrt{2}}{\pi} = 0.287$$

However, due to saturation effects produced by the flow of direct current through the transformer secondary, the value of *TUF* is further reduced to 0.2.

Obviously, dc power delivered to the load = ac transformer rating \times *TUF*

If, we have a 1-kVA transformer, then the power which it would be able to deliver to a resistive load in a half-wave rectifier without over-heating would be = $0.2 \times 1000 = 200$ W.

Example 55.1. In the half-wave rectifier circuit of Fig. 55.4, determine

- (i) maximum and rms values of load voltage,
- (ii) peak and rms values of load current,
- (iii) power absorbed by the load,
- (iv) PIV of the diode,
- (v) rms value of ripple voltage.

Neglect resistance of transformer secondary and that of the diode.



Solution. Here, $K = N_2/N_1 = 1/10$. Peak primary voltage is

$$V_{pm} = 220\sqrt{2} = 310 \text{ V.}$$

Hence,

$$V_{sm} = KV_{pm} = 310/10 = \mathbf{31 \text{ V}}$$

(i) $V_{LM} = V_{sm} = \mathbf{31 \text{ V}}$

$$V_L = V_{LM}/2 = 31/2 = \mathbf{15.5 \text{ V}}$$

(ii) $I_{LM} = V_{LM}/R_L = 31/100 = \mathbf{0.31 \text{ A}}$

$$I_L = I_{LM}/2 = 0.31/2 = \mathbf{0.155 \text{ A}}$$

(iii) $P_L = V_L I_L = 15.5 \times 0.155 = \mathbf{2.4 \text{ W}}$

(iv) $P_{IV} = 2 V_{sm} = 2 \times 31 = \mathbf{62 \text{ W}}$

(v) $V_{L(ac)} = \sqrt{V_L^2 - V_{L(dc)}^2}$

Now, $V_L = V_{LM}/2$ and $V_{L(dc)} = V_{LM}/\pi$

$$\therefore V_{L(ac)} = \sqrt{(V_{LM}/2)^2 - (V_{LM}/\pi)^2} = 0.385 V_{LM}$$

$$\therefore V_{r(rms)} = V_{L(ac)} = 0.385 \times 31 = \mathbf{11.9 \text{ V}}$$

It represents the rms value of the ripple voltage.

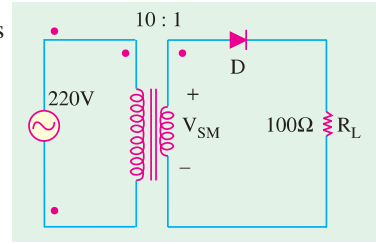

Fig. 55.4

55.6. Equivalent Circuit of a HW Rectifier

Such a circuit is shown in Fig. 55.5. Here, the diode has been replaced by its equivalent circuit (Art. 55.13). The transformer secondary of Fig. 55.2 has been replaced by an ac sinusoidal generator having a peak value of V_{sm} . Resistance R_s represents transformer secondary resistance. Obviously,

$$I_{LM} = \frac{V_{sm} - V_B}{(R_s + r_d) + R_L} = \frac{V_{sm} - V_B}{R_0 + R_L}$$

$$V_{LM} = I_{LM} \cdot R_L$$

$$V_{L(dc)} = V_{LM}/\pi, I_{L(dc)} = I_{LM}/\pi$$

$$V_L = V_{LM}/2 \text{ and } I_L = I_{LM}/2$$

(i) $\eta = \left(\frac{4}{\pi^2} \right) \frac{R_L}{(R_s + r_d) + R_L}$

$$= \left(\frac{4}{\pi^2} \right) \frac{R_L}{R_0 + R_L} = \frac{40.6\%}{1 + R_0/R_L}$$

(ii) Voltage regulation is given by

$$V_R = \frac{V_{NL} - V_{FL}}{V_{FL}} \times 100$$

(iii) Under no-load condition *i.e.* when no output current flows, the voltage has maximum value. When rectifier is fully loaded *i.e.* when output current flows, there is drop over R_0 . Hence, output voltage is decreased by this much amount.

$$V_{FL} = V_{NL} \frac{R_L}{R_0 + R_L}$$

Substituting this value in the above equation, we get $V_R = R_0/R_L$

Example 55.2. A half-wave rectifier using silicon diode has a secondary emf of 14.14 V (rms) with a resistance of 0.2 Ω. The diode has a forward resistance of 0.05 Ω and a threshold voltage of 0.7 V. If load resistance is 10 Ω, determine



(i) dc load current (ii) dc load voltage (iii) voltage regulation and (iv) efficiency.
 (Applied Electronics-I, Punjab University, 1992)

Solution.

$$V_{sm} = \sqrt{2} \times 14.14 = 20 \text{ V}, R_0 = 0.2 + 0.05 = 0.25 \Omega$$

(i) $I_{LM} = \frac{V_{sm} - V_B}{R_0 + R_L} = \frac{20 - 0.7}{10.25} = 1.88 \text{ A}; I_{L(dc)} = \frac{I_{LM}}{\pi} = \frac{1.88}{\pi} = 0.6 \text{ A}$

(ii) $V_{L(dc)} = I_{L(dc)} \cdot R_L = 0.6 \times 10 = 6 \text{ V}$

(iii) $V_R = R_0/R_L = 0.25/10 = 0.025$ or **2.5%**

(iv) $\eta = \frac{40.6}{1 + 0.25/10} = 39.6\%$

55.7. Single-phase Full-wave Rectifier

In this case, both half-cycles of the input are utilized with the help of two diodes working alternately. For full-wave rectification, use of a transformer is essential (though it is optional for half-wave rectification).

The full-wave rectifier circuit using two diodes and a centre-tapped transformer shown in 55.6 (a). The centre-tap is usually taken as the ground or zero voltage reference point.

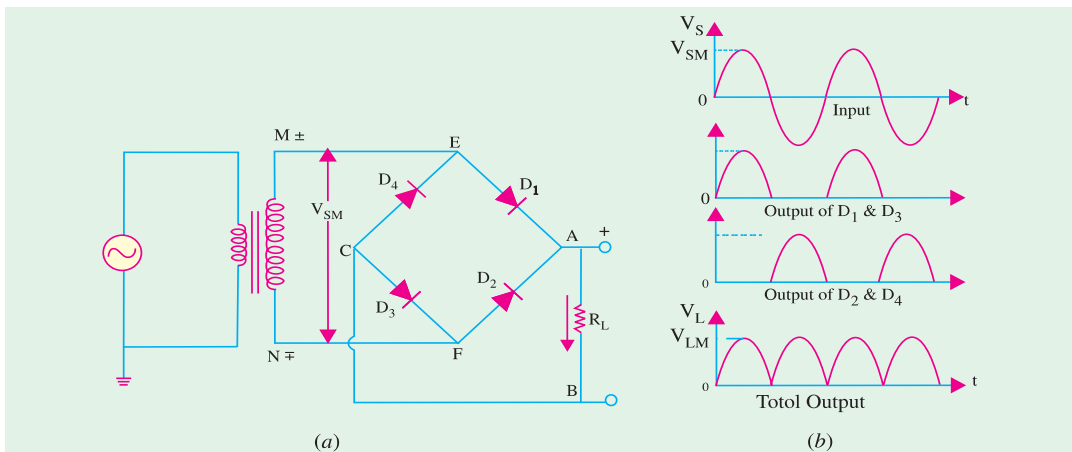

Fig. 55.6

Fig. 55.7 shows two different ways of drawing the circuit. In Fig. 55.7 (a), R_L becomes connected to point G via the earth whereas in Fig. 55.7 (b). It is connected directly to G.

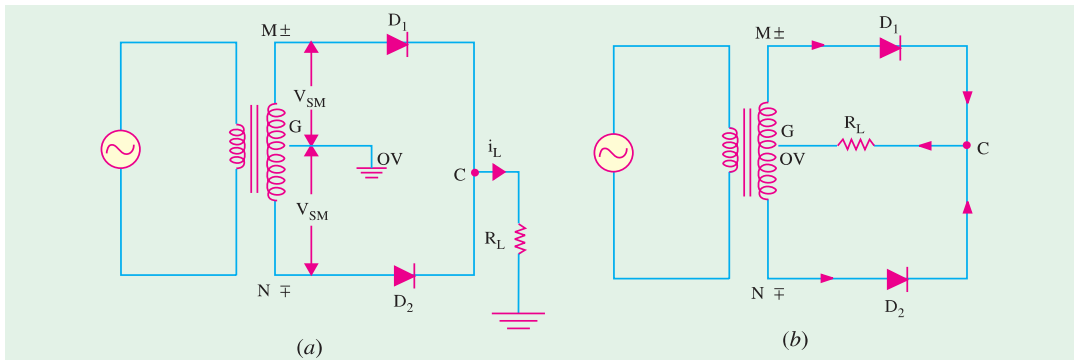

Fig. 55.7



(a) Working

When input ac supply is switched on, the ends M and N of the transformer secondary become +ve and -ve alternately. During the positive half-cycle of the ac input, terminal M is +ve, G is at zero potential and N is at -ve potential. Hence, being forward-biased, diode D_1 conducts (but not D_2 which is reverse-biased) and current flows along MD_1CABG . As a result, positive half-cycle of the voltage appears across R_L .

During the negative half-cycle, when terminal N becomes +ve, then D_2 conducts (but not D_1) and current flows along ND_2CABG . So, we find that current keeps on flowing through R_L in the same direction (i.e. from A to B) in both half-cycles of ac input. It means that both half-cycles of the input ac supply are utilized as shown in Fig. 55.6 (b). Also, the frequency of the rectified output voltage is twice the supply frequency. Of course, this rectified output consists of a dc component and many ac components of diminishing amplitudes.

(b) Average and RMS Values

As proved earlier in and now shown in Fig. 5.8

$$V_L = V_{LM}/\sqrt{2} = 0.707 V_{LM}; V_{L(dc)} = 2 V_{LM}/\pi = 0.636 V_{LM}$$

$$V_{L(ac)} = \text{rms value of ac components in the output voltage}$$

$$= \sqrt{V_L^2 - V_{L(dc)}^2}$$

Similarly,

$$I_{LM} = \frac{V_{LM}}{R_L}; I_L = \frac{I_{LM}}{\sqrt{2}} = 0.707 I_{LM}$$

$$I_{L(dc)} = \frac{2 I_{LM}}{\pi} = 0.636 I_{LM}; I_{L(ac)} = \sqrt{I_L^2 - I_{L(dc)}^2}$$

Incidentally, $I_{L(ac)}$ is the same thing as $I_{r(rms)}$.

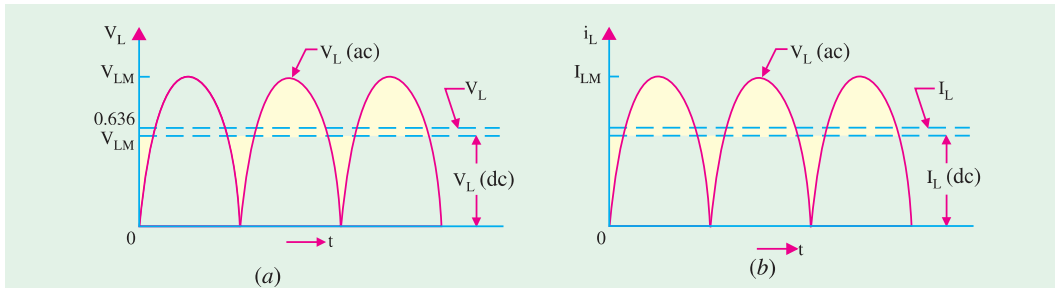

Fig. 55.8

(c) Efficiency

$$P_{in} = I_L^2 (R_0 + R_L) = \left(\frac{I_{LM}}{\sqrt{2}} \right)^2 (R_0 + R_L) = \frac{1}{2} I_{LM}^2 (R_0 + R_L)$$

$$P_{dc} = I_{L(dc)}^2 (R_0 + R_L) = \left(\frac{2 I_{LM}}{\pi} \right)^2 (R_0 + R_L) = \frac{4 I_{LM}^2}{\pi^2} (R_0 + R_L)$$

$$\therefore \eta = \frac{P_{dc}}{P_{in}} = \left(\frac{8}{\pi^2} \right) \left(\frac{R_L}{R_0 + R_L} \right) = \frac{0.812}{(1 + R_0/R_L)} = \frac{81.2\%}{(1 + R_0/R_L)}$$

It is twice the value for the half-wave rectifier for the simple reason that a full-wave rectifier utilizes both half-cycles of the input ac supply.

(d) Frequency Components

As in the case of a HW rectifier, the output of a full-wave rectifier also consists of (i) a dc



component and (ii) a number of ac components which form the ripple. The Fourier series for rectifier output voltage is

$$V_L = V_{LM} \left(\frac{2}{\pi} - \frac{4}{3\pi} \cos 2\omega t - \frac{4}{15\pi} \cos 4\omega t - \frac{4}{35} \cos 6\omega t - \dots \right)$$

As seen, $V_{L(dc)} = \frac{2V_{LM}}{\pi}$; $V_{L1} = \frac{4V_{LM}}{\sqrt{2} \cdot 3\pi}$, $V_{L2} = \frac{4V_{LM}}{\sqrt{2} \cdot 15\pi}$ etc.

$$V_{L(ac)} = \sqrt{V_{L1}^2 + V_{L2}^2} = \sqrt{\left(\frac{4V_{LM}}{\sqrt{2} \cdot 3\pi}\right)^2 + \left(\frac{4V_{LM}}{\sqrt{2} \cdot 15\pi}\right)^2} = 0.305 V_{LM}$$

Similarly, $I_{L(ac)} = I_{r(rms)} = \sqrt{I_{L1}^2 + I_{L2}^2} = 0.305 I_{LM}$

(e) Ripple Factor

$$\gamma = \frac{V_{L(ac)}}{V_{L(dc)}} = \frac{V_{r(rms)}}{V_{L(rms)}} = \frac{0.305 V_{LM}}{0.636 V_{LM}} = 0.482$$

It is much less as compared to 1.21 for half-wave rectifier.

(f) PIV

Its value is $= 2 V_{sm}$

(g) TUF

Its value is found by considering the primary and secondary windings of the transformer separately. Its value is 0.693 (as compared to 0.287 for a half-wave rectifier). In such a rectifier, there is no problem due to dc saturation of flux in the core because the dc currents in the two halves of the secondary flow in opposite directions.

Example 55.3. With reference to the full-wave rectifier of Fig. 55.9, determine

- (i) peak, dc component, rms and ac component of load voltage,
 - (ii) peak, dc component, rms and ac component of load current,
 - (iii) ripple factor,
 - (iv) peak and average diode currents,
 - (v) total power supplied to the load.
- Neglect diode and secondary winding resistances.

Solution. Here,

$$K = 1/2$$

$$V_{pm} = 220 = 312 \text{ V. Hence,}$$

$$V_{MN} = 312/2 = 156 \text{ V so that}$$

$$V_{MG} = V_{GN} = 156/2 = 78 \text{ V}$$

$$V_{sm} = V_{LM} = 78 \text{ V}$$

$$V_{L(dc)} = 0.636 V_{LM} = 0.636 \times 78$$

$$= 49.6 \text{ V}$$

$$V_L = 0.707 V_{LM} = 0.707 \times 78$$

$$= 55 \text{ V}$$

$$V_{L(ac)} = \sqrt{55^2 - 49.6^2} = 23.8 \text{ V}$$

It also represents $V_{r(rms)}$.

(ii) $I_{LM} = V_{LM}/R_L = 78/100 = 0.78 \text{ A}$

$$I_{L(dc)} = 0.636 \times 0.78 = 0.496 \text{ A}$$

$$I_L = 0.707 \times 0.78 = 0.55 \text{ A}$$

$$I_{L(ac)} = \sqrt{0.55^2 - 0.496^2} = 0.238 \text{ A}$$

It also represents $I_{r(rms)}$.

(iii) $\gamma = \frac{I_{L(ac)}}{I_{L(dc)}} = \frac{I_{r(max)}}{I_{L(max)}} = \frac{0.238}{0.496} = 0.48$

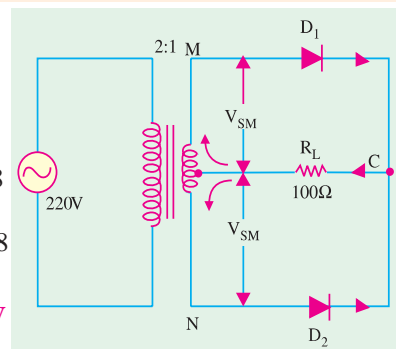

Fig. 55.9



(iv) peak diode current = peak load current = **0.78 A**

For finding the average current of a diode, it must be remembered that each diode carries current for one half-cycle only.

$$I_{D(av)} = I_{D(max)}/\pi = 0.318 \times 0.78 = \mathbf{0.25 \text{ A}}$$

(v) $PL = V_L I_L = 55 \times 0.55 = \mathbf{30.25 \text{ W}}$

Example 55.4. A 1- ϕ , full-wave rectifier supplies power to a 1 k W load. The ac voltage applied to the diode is 300-0-300 V (rms). If diode resistance is 25 Ω and that of the transformer secondary negligible, determine“

- (i) average load current, (ii) average value of load voltage,
 (iii) rms value of ripple, (iv) efficiency.

(Applied Electronics, Bombay Univ.)

Solution. It may be noted that rms value of ac voltage across each secondary half is 300 V.

(i) $V_{sm} = 300 = 424 \text{ V}, I_{LM} = V_{sm}/(r_d + R_L) = 424/1025 = 0.414 \text{ A}$

$$I_{L(dc)} = I_{LM}/\pi = 2 \times 0.414/\pi = \mathbf{0.263 \text{ A}}$$

(ii) $V_{L(dc)} = I_{L(dc)} \cdot R_L = 0.263 \times 1000 = \mathbf{263 \text{ V}}$

(iii)
$$\gamma = \frac{V_{L(ac)}}{V_{L(dc)}} = \frac{V_{r(rms)}}{V_{L(dc)}}$$

$\therefore V_{r(rms)} = \gamma \cdot V_{L(dc)} = 0.482 \times 263 = \mathbf{126.8 \text{ V}}$

(iv)
$$\eta = \frac{81.2\%}{1 + r_d / R_L} = \frac{81.2\%}{1 + 25/1000} = \mathbf{79.2\%}$$

Example 55.5. A full-wave rectifier is built up by using the same components as in Ex. 55.2. Determine :

- (i) dc load current, (ii) dc load voltage,
 (iii) voltage regulation, (iv) circuit efficiency and
 (v) diode PIV and current rating.

Solution.

(i) $I_{L(dc)} = 0.636 \times 1.88 = \mathbf{1.2 \text{ A}}$

(ii) $V_{L(dc)} = I_{L(dc)} \cdot R_L = 1.2 \times 10 = \mathbf{12 \text{ V}}$

(iii) $VR = 0.25/10 = 0.025$ or **2.5%**

(iv)
$$\eta = \frac{81.2\%}{1 + R_0 / R_L} = \frac{81.2\%}{1 + 0.25/10} = \mathbf{79.2 \%$$

(v) $PIV = 2 V_{sm} = 2 \times 20 = \mathbf{40 \text{ V}}$

With a safety factor of 1.5, $PIV = 40 \times 1.5 = 60 \text{ V}$. A dc current rating of about 2 A would be satisfactory.

Example 55.6. Silicon diodes are used in a two-diode full-wave rectifier circuit to supply a load with 12 volts D.C. Assuming ideal diodes and that the load resistance is 12 ohms, compute (i) the transformer secondary voltage, (ii) the load ripple voltage, (iii) the efficiency of the rectifier. Derive equations used. (Electronics-I, Bangalore Univ.)

Solution.

(i) $V_{L(dc)} = 2 V_{sm}/\pi; \quad V_{sm} = \pi \times 12/2 = \mathbf{18.8 \text{ V}}$

It is the maximum value of the voltage across one half of the secondary.

(ii) RMS value of ripple voltage = $\gamma V_{L(dc)} = 0.482 \times 12 = \mathbf{5.78 \text{ V}}$

(iii) Since diodes are ideal ones, their forward resistance is negligible. Hence,



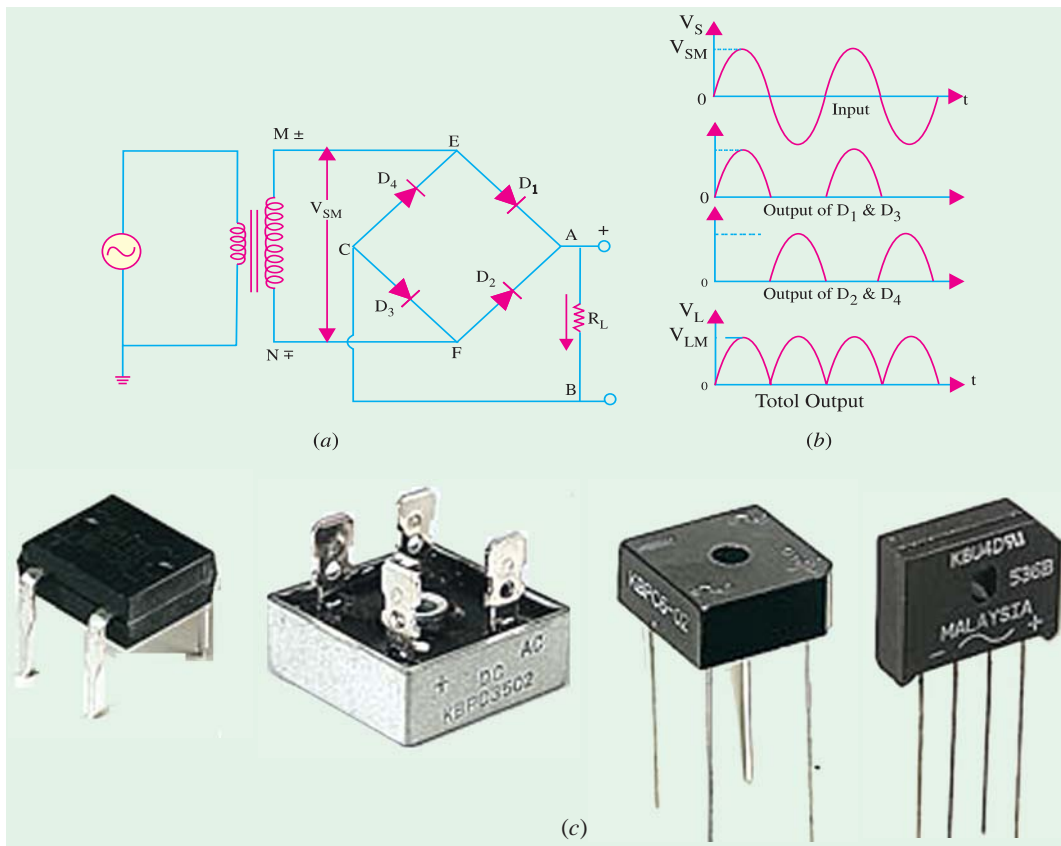

Fig. 55.10

$$\eta = \frac{81.2\%}{(1 + r_d / R_L)} = \frac{81.2\%}{1 + 0/12} = 81.2\%$$

55.8. Full-Wave Bridge Rectifier

It is the most frequently-used circuit for electronic dc power supplies. It requires four diodes but the transformer used is not centre-tapped and has a maximum voltage of V_{sm} . The full-wave bridge-rectifier is available in three distinct physics forms.

1. four discrete diodes,
2. one device inside a four-terminal case,
3. as part of an array of diodes in an IC.

The circuit using four discrete diodes is shown in Fig. 55.10 (a) and 55.10 (c) shows some pictures of the bridge rectifier available as one device in a four terminal case.

(a) Working

During the positive input half-cycle, terminal M of the secondary is positive and N is negative as shown separately in Fig. 55.11 (a). Diodes D_1 and D_3 become forward-biased (ON) whereas D_2 and D_4 are reverse-biased (OFF). Hence, current flows along $MEABCFN$ producing a drop across R_L .

During the negative input half-cycle, secondary terminal N becomes positive and M negative. Now, D_2 and D_4 are forward-biased. Circuit current flows along $NFABCEM$ as shown in Fig. 55.11 (b). Hence, we find that current keeps flowing through load resistance R_L in the same direction AB during both half-cycles of the ac input supply. Consequently, point A of the bridge rectifier always



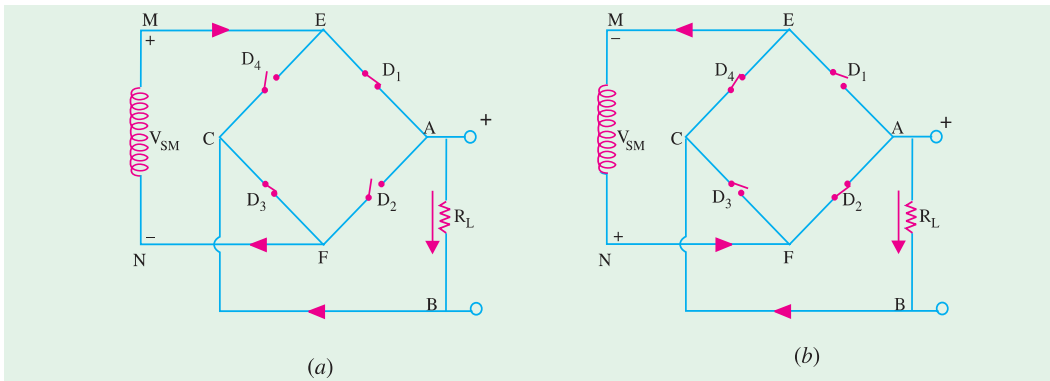

Fig. 55.11

acts as an anode and point C as cathode. The output voltage across R_L is as shown in Fig. 55.10 (b). Its frequency is twice that of the supply frequency.

(b) Average and RMS Values

These are the same as for the centre-tapped full-wave rectifier discussed in Art 55.7.

(c) Efficiency

$$\% \eta = \frac{81.2}{1 + 2 r_d / R_L}$$

(d) Ripple Factor

It is the same as for a full-wave rectifier *i.e.* $\gamma = 0.482$

(e) PIV

The *PIV* rating of each of the four diodes is equal to V_{SM} —the entire voltage across the secondary.

When Secondary and Diode Resistances are considered

(i) $I_{LM} = \frac{V_{sm} - 2V_B}{(R_S + 2r_d) + R_L} = \frac{V_{sm} - 2V_B}{R_0 + R_L}$ (ii) $V_{LM} = I_{LM} \cdot R_L$

(iii) $\eta = \left(\frac{8}{\pi^2}\right) \left(\frac{R_L}{(R_S + 2r_d + R_L)}\right) = \left(\frac{8}{\pi^2}\right) \frac{R_L}{R_0 + R_L}$

(iv) $V_R = \frac{R_S + 2r_d}{R_L} = \frac{R_0}{R_L}$

(f) Advantages

After the advent of low-cost, highly-reliable and small-sized silicon diodes, bridge circuit has become much more popular than the centre-tapped transformer *FW* rectifier. The main reason for this is that for a bridge rectifier, a much smaller transformer is required for the same output because it utilizes the transformer secondary continuously unlike the 2-diode *FW* rectifier which uses the two halves of the secondary alternately.

So, the advantages of the bridge rectifier are :

1. no centre-tap is required on the transformer;
2. much smaller transformers are required;
3. it is suitable for high-voltage applications ;
4. it has less *PIV* rating per diode.

The obvious disadvantage is the need for twice as many diodes as for the centre-tapped transformer version. But ready availability of low-cost silicon diodes has made it more economical despite its requirement of four diodes.



55.9. Three-phase Half-wave Rectifier

Rectification of a 3-phase supply with the help of diodes is shown in Fig. 55.12 along with a smoothing circuit. The three diodes are connected to the three phases of star-connected secondary of a 3-phase transformer. Neutral point N of the secondary is the negative terminal for the rectified output and is earthed as shown.

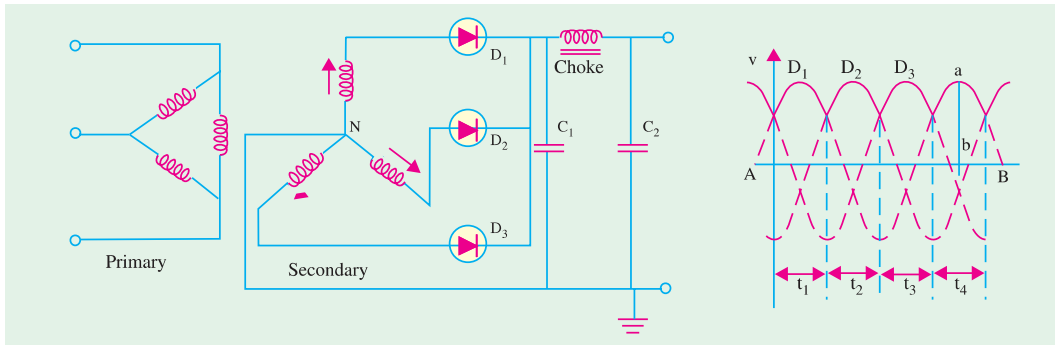

Fig. 55.12

Fig. 55.13

The shape of the output is shown in Fig. 55.13. The horizontal line AB represents the potential of the negative d.c. terminal output and the sine waves 1, 2 and 3 each represent the anode potentials of the three diodes.

During one-third of the cycle *i.e.*, during time t_1 , only diode D_1 will conduct. It will cease conducting at t_2 and then D_2 will conduct current upto t_2 after which D_2 will take over and will supply anode current till t_3 . When one diode conducts, the other two remain inactive because then their anodes are more $-ve$ than their cathodes. This process repeats itself during each ensuing cycle, with the conducting period of each diode being as indicated. The output is given by the vertical distance 'ab' between the upper envelope and the line AB . Obviously, the output fluctuates between the maximum and minimum values thrice in each cycle. The variations of output lie between V_{sm} and $0.5 V_{sm}$ (neglecting voltage drop in diodes) and has a mean value of $V_{dc} = 0.83 V_{sm}$ or $1.17 V_S$ where V_S is the r.m.s. value of the secondary phase voltage. Its maximum conversion $\eta = 96.5\%$ and $\gamma = 0.17$. But it should be noted that the magnitude of these fluctuations or pulsations is lesser than for a 1-phase, full-wave rectified output since the current never touches zero. It is further smoothed up by a $C-L-C$ filter circuit as shown in Fig. 55.12.

It is seen that direct current of each diode appears in the secondary phase winding and so causes transformer saturation resulting in large primary current. It can be avoided by using zig-zag secondary.

55.10. Full-wave Rectification of 3-phase Currents

As shown in Fig. 55.14, a three-phase full-wave rectifier requires a transformer with six secondary windings connected to give two separate three-phase supplies 180° out of phase with each other. The centre taps are connected by an interphase transformer which enables the two rectifier units to operate independently of each

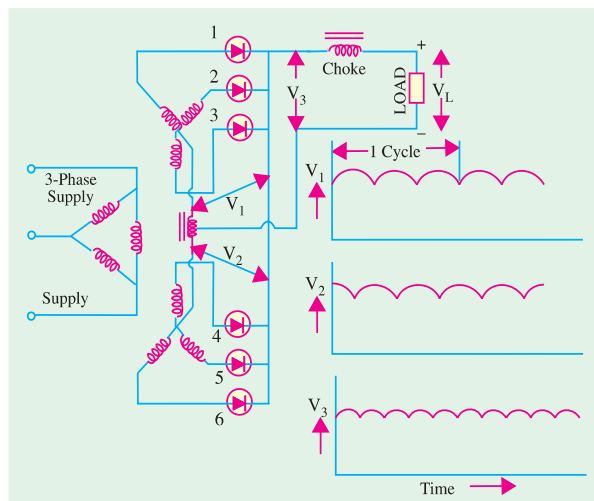

Fig. 55.14



other. Obviously, each diode conducts for one-third cycle. However, the addition of two outputs cancels the lowest frequency component of the ripple.

The output voltage has a mean value of $0.83 V_{sm}$ (less the diode voltage drop) and a ripple having a fundamental frequency six times the supply frequency.

Three-phase full-wave rectifier circuit is preferred for high powers because

- (i) each secondary carries current for one-third of a cycle;
- (ii) each primary carries current for two-thirds of a cycle;
- (iii) Cu loss in the transformer windings is comparatively lower.

55.11. Six-phase Half-wave Rectifier

Such a rectifier can be operated from a 3-phase supply using a transformer with three centre-tapped secondary windings with all the centre taps connected together as shown in Fig. 55.15. Obviously, each diode conducts for one-sixth of a cycle. The output voltage has a mean value of $0.955 V_{sm}$ (less the voltage drop in the diode). Ripple has a very small value and a fundamental frequency six times the supply frequency.

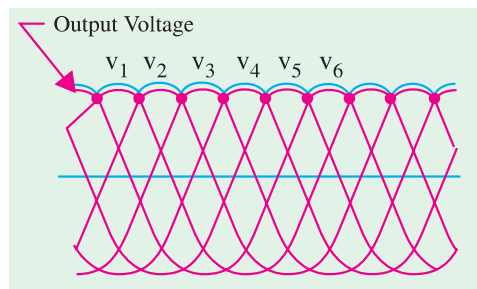

Fig. 55.15

55.12. Three-phase Bridge Circuit

This circuit is very frequently used because apart from being simple, it does not require centre-tap transformer. Only that diode supplies the load whose phase voltage is more positive than the others. For example, when D_1 is forward-biased, D_2 and D_3 are reverse-biased. The current returns to the supply via D_5 and D_6 .

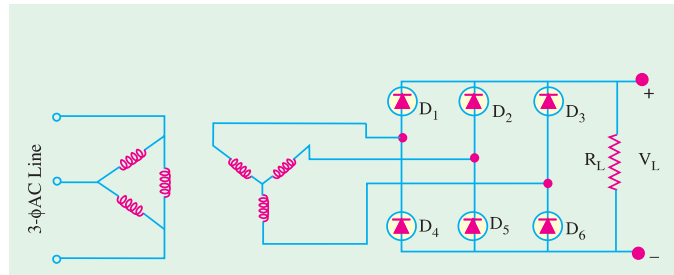

Fig. 55.16

In this circuit, I_{dc} is 0.955 times the peak current through each diode and only one-third of it flows through each diode (rather than one-sixth as in Fig. 5.15). Similarly, V_{dc} is twice of that in 3- ϕ , half-wave rectifier or $2 \times 1.17 = 2.34$ times the r.m.s. a.c. voltage across each secondary leg. Accordingly, r.m.s. voltage across each secondary leg need be only $1/2.34 = 0.428$ times the desired d.c. output voltage.

Example 55.7. The r.m.s. value of transformer secondary voltage per leg (V_s) in a full-wave, D/Y , 6-f rectifier is 150 V. If average value of load current is 2 A, find (i) V_{dc} (ii) peak and average current through each diode and (iii) average power delivered to the load i.e. P_{dc} .

- Solution.** (i) $V_{dc} = 2.34 \times V_s = 2.34 \times 150 = 351 \text{ V}$
 (ii) peak current/diode = $(1/0.955) \times I_{dc} = 1.05 \times 2 = 2.1 \text{ A}$
 average d.c. current/diode = $2/3 = 0.667 \text{ A}$
 (In D/Y half-wave rectifier, its value is 1/6th rather than 1/3rd)
 (iii) $P_{dc} = V_{dc} I_{dc} = 351 \times 2 = 702 \text{ W}$

55.13. Calculations with Resistive Load

Let us suppose that no filter is connected across the rectifier (Fig. 55.12) but only a load of



resistance R . Further, we will neglect transformer resistance and leakage and internal diode drops. In that case,

$$\begin{aligned}
 V_{dc} &= 0.827 V_{sm}; I_{dc} = 0.827 V_{sm}/R \\
 P_{dc} &= V_{dc} I_{dc} = (0.827 V_{sm})^2/R; & P_{ac} = P_{in} = 0.706 V_{sm}^2/R \\
 \therefore \text{rectifier } \eta &= \frac{P_{dc}}{P_{ac}} = \frac{(0.827 V_{sm})^2/R}{0.706 V_{sm}^2/R} = 0.965 = 96.5\% \\
 \gamma &= \sqrt{(1.014)^2 - 1} = 0.17 \text{ or } 17\%.
 \end{aligned}$$

Conclusions

Here, average d.c. current is 0.827 times the peak current as compared to 0.318 times for 1- ϕ , half-wave circuit and 0.636 times for 1- ϕ , full-wave circuit. Moreover, V_{dc} is also correspondingly high, it is 51.17 times the r.m.s. voltage of each secondary leg ($\because 1.414 \times 0.827 = 1.17$). Conversely, r.m.s. voltage (V_s) across each leg of the secondary need only be $1/1.17 = 0.855$ times the average desired d.c. output voltage across the load.

55.14. Filters

The main function of a filter circuit (Fig. 55.17) is to minimize the ripple content in the rectifier output.

As seen, output of various rectifier circuits is pulsating. It has a dc value and some ac components called ripples. This type of output is not useful for driving sophisticated electronic circuits/devices. In fact, these circuits require a very steady dc output that approaches the smoothness of a battery's output.

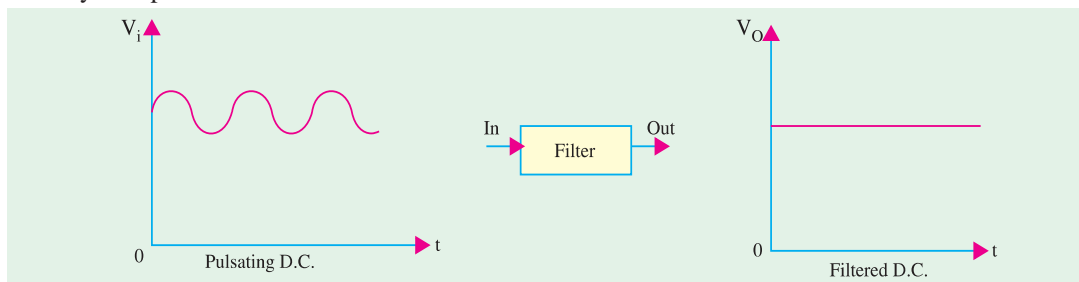

Fig. 55.17

A circuit that converts a pulsating output from a rectifier into a very steady dc level is known as filter because it filters out or smoothens out the pulsations in the output.

We will consider the following popular filter circuits :

1. Series capacitor filter,
2. series inductor filter,
3. L - C filter (or L -type),
4. R - C filter,
5. R - L - C filter.

55.15. Shunt Capacitor Filter

In this circuit, a suitable single capacitor C is connected across the rectifier and in parallel with the load R_L to achieve filtering action. This type of filter is known as **capacitor input filter**.

This filter circuit depends for its operation on the property of a capacitor to charge up (*i.e.* store energy) during conducting half-cycle and to discharge (*i.e.* deliver energy) during the non-conducting half-cycle. In simple words, a capacitor opposes any change in voltage. When connected across a pulsating d.c. voltage, it tends to smoothen out or filter out the voltage pulsations (or ripples). The filtering action of the simple capacitor filter when used in a half-wave rectifier can be understood with the help of Fig. 55.18.



(a) Circuit Analysis

When positive half-cycle of the ac input is applied, the diode is forward-biased and hence is turned ON. This allows C to quickly charge up to peak value of input voltage V_{ip} [point b in Fig. 55.18 (b)] because charging time constant is almost zero. It is so because there is no resistance in the charging path except diode forward resistance which is negligible. Hence, capacitor follows the charging voltage as shown. After being fully charged, the capacitor holds the charge till input ac supply to the rectifier goes negative. During the negative half-cycle, the capacitor attempts to discharge. However, it cannot discharge through diode which, being now reverse-biased, is OFF. Hence, it discharges through R_L from point b to c in Fig. 55.18 (c) and its voltage decreases somewhat. The discharging time constant ($= CR_L$) is usually 100 times more than the charging time. Hence, C does not have sufficient time to discharge appreciably. It is seen that even during negative half-cycle of the input supply, the capacitor maintains a sufficiently large voltage across R_L .

During the next positive half-cycle, when rectifier voltage exceeds the capacitor voltage represented by point c in Fig. 55.18 (c), C is again charged quickly to V_{ip} as represented by point d . Once more, input voltage goes negative, opening the diode and forcing C to discharge through R_L during the interval de . In

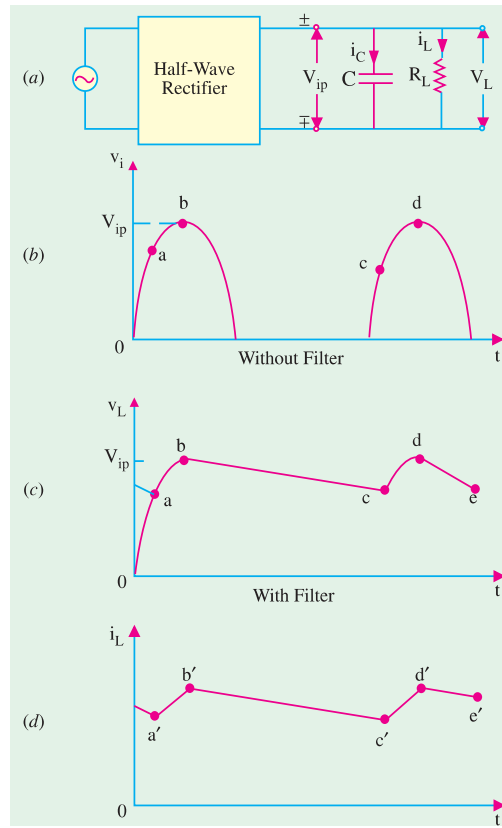

Fig. 55.18

this way, R_L sees a nearly constant dc voltage across it at all times.

The filtering action of this simple capacitor filter on a full-wave rectifier is shown in Fig. 55.19. It is seen that as compared to a HW rectifier,

- (i) dc load voltage increases slightly towards V_{ip} ,
- (ii) ripple voltage has been reduced by half.

The decreased ripple is because of shorter discharge time before the capacitor is reenergised by another pulse of current.

(b) Load Current

The load current has the same wave-shape as v_L because load is purely resistive. It is shown in Fig. 55.18 (d). During periods $d'b'$ and $c'd'$ etc., current is supplied by the diode and during periods $b'c'$ and $d'e'$ etc. by the capacitor.

(c) Diode Current

Diode current flows during short intervals of time like ab and cd etc. in Fig. 55.18 (c) which is reproduced in Fig. 55.20. During these intervals, diode

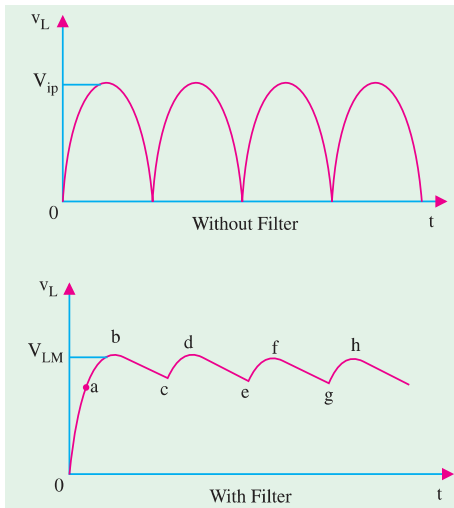

Fig. 55.19

During these intervals, diode



output voltage is greater than the capacitor voltage which is also the load voltage. Hence, diode current is a surging current *i.e.* it takes the form of short-duration pulses as shown in Fig. 55.20. A small resistor is always connected in series with the diode to limit this surge current. It is known as surge limiting resistor.

The sole function of the diode is to recharge C and the sole function of C is to supply load current by discharge.

55.16. Effect of Increasing Filter Capacitance

A capacitor has the basic property of opposing changes in voltage. Hence, a bigger capacitor would tend to reduce the ripple magnitude. It has been found that increasing the capacitor size.

1. increases V_{dc} towards the limiting value V_{ip} ;
2. reduces the magnitude of ripple voltage ;
3. reduces the time of flow of current pulse through the diode ;
4. increases the peak current in the diode.

55.17. Calculations of Shunt Capacitor Filter

Consider the rectifier and filter circuit of Fig. 55.21 where a capacitor has been connected across R_L . The output voltage waveforms of a half-wave rectifier with a shunt capacitor filter are shown in Fig. 55.22 (a) whereas Fig. 55.22 (b) shows those for a full-wave rectifier. The ripple voltage which occurs under light load conditions can be approximated by a triangular wave which has a peak-to-peak value of $V_{r(p-p)}$ and a time period of T_r^* centred around the dc level.

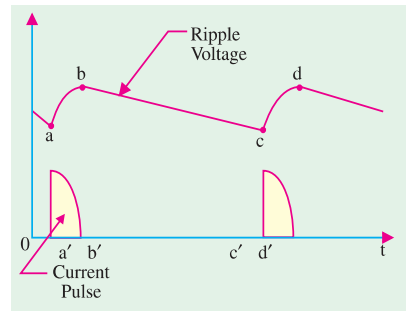

Fig. 55.20

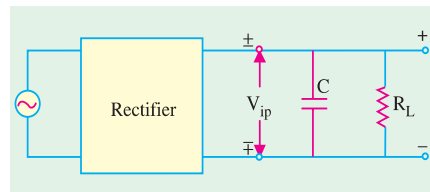

Fig. 55.21

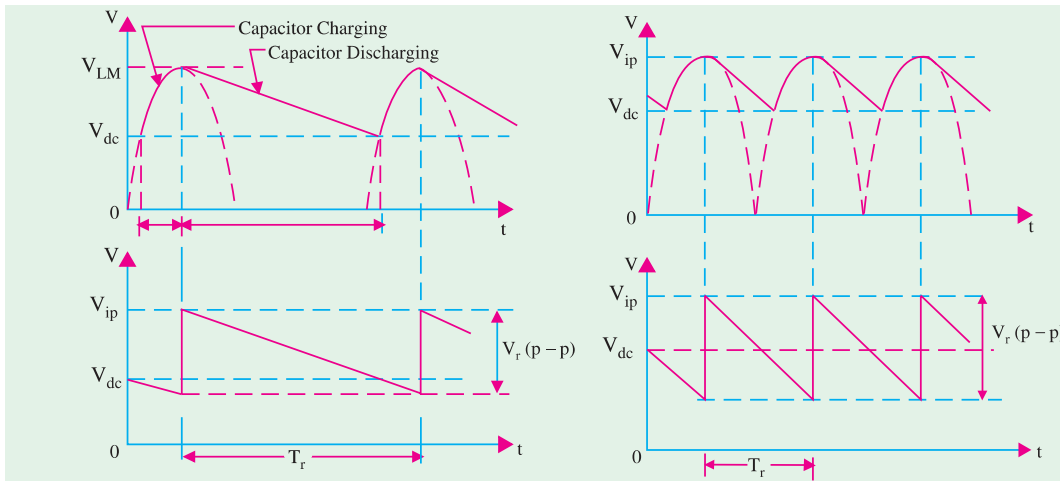

Fig. 55.22

In fact, $V_{r(p-p)}$ is the amount by which capacitor voltage falls during discharge period T_r . This discharge is actually exponential** but can be approximated by a straight line discharge if we assume

* Since charging time is negligibly small, the approximate discharging time represents the full time-period.

** given by $V_c = V_{ip} e^{-t/CR_L}$



the discharge rate to remain constant at the dc level I_{dc} . In that case, charge lost dQ in time T_r is $I_{dc} T_r$

$$\therefore V_{r(p-p)} = \frac{dQ}{C} = \frac{I_{dc} T_r}{C} = \frac{V_{dc}}{f_r C R_L} \quad \left(\because I_{dc} = \frac{V_{dc}}{R_L} \right)$$

The triangular ripple has an rms value given by $V_{r(rms)} = V_{r(p-p)} / 2\sqrt{3}$

$$\therefore V_{r(rms)} = \frac{V_{r(p-p)}}{2\sqrt{3}} = \frac{V_{dc}}{2\sqrt{3} f_r C R_L} \quad \therefore \gamma = \frac{V_{r(rms)}}{V_{dc}} = \frac{1}{2\sqrt{3} f_r C R_L}$$

Now, f_r is the frequency of the ripple voltage. For a half-wave rectifier, f_r equals the rectifier line input frequency whereas it is double the line input frequency for a full-wave rectifier. If f is the line frequency, then

$$\begin{aligned} \gamma &\cong \frac{1}{2\sqrt{3} f C R_L} && \text{— for HW rectifier} \\ &\cong \frac{1}{4\sqrt{3} f C R_L} && \text{— for FW rectifier} \end{aligned}$$

It can be further proved that

$$\begin{aligned} \gamma &= \frac{1}{2\sqrt{3} f C R_L} = \frac{I_{dc}}{4\sqrt{3} f C} \left(\frac{1}{V_{ip}} - \frac{1}{V_{dc}} \right) && \text{— half-wave rectifier} \\ &= \frac{1}{4\sqrt{3} f C R_L} = \frac{I_{dc}}{4\sqrt{3} f C V_{ip}} && \text{— for full-wave rectifier} \end{aligned}$$

It is seen from above that ripple increases with increase in load (*i.e.* output) current.

Incidentally,
$$V_{dc} = V_{ip} - \frac{V_{r(p-p)}}{2}$$

where V_{ip} = peak rectifier output voltage.

Substituting the value of $V_{r(p-p)} = V_{dc} / f_r C R_L$, we get

$$V_{dc} = V_{ip} - \frac{V_{dc}}{2 f_r C R_L} \quad \text{or} \quad V_{dc} = \frac{V_{ip}}{1 + \frac{1}{2 f_r C R_L}}$$

$$\begin{aligned} \therefore V_{dc} &= V_{ip} = \left(\frac{2 f C R_L}{1 + 2 f C R_L} \right) = \frac{V_{ip} - I_{dc} / 4 f C}{1 + I_{dc} / 4 f C V_{ip}} && \text{— half-wave rectifier} \\ &= V_{ip} \left(\frac{4 f C R_L}{1 + 4 f C R_L} \right) = \frac{V_{ip}}{1 + I_{dc} / 4 f C V_{ip}} && \text{— full-wave rectifier} \end{aligned}$$

Example 55.8. A half-wave rectifier has a peak output voltage of 12.2 V at 50 Hz and feeds a resistive load of 100 Ω. Determine (i) the value of the shunt capacitor to give 1 percent ripple factor and (ii) the resulting dc voltage across the load resistor.

Solution. (i)
$$\gamma = 1/2\sqrt{3} f C R_L \quad \text{or} \quad 0.01 = 1/2\sqrt{3} \quad \therefore C = 5770 \mu\text{F}$$

(ii)
$$V_{dc} = \frac{V_{ip}}{1 + 1/2 f C R_L} = \frac{12.2}{1 + 1/2 \times 5770 \times 10^{-6} \times 100} = 12 \text{ V}$$

Example 55.9. Find the ripple factor and dc output voltage for the filtered bridge rectifier shown in Fig. 55.23. Each silicon diode has a threshold voltage of 0.7 V.

Solution. Peak primary voltage = $230 \times \sqrt{3}$
= 325 V



$$\begin{aligned} \text{Peak secondary voltage} &= 325 \times 1/10 \\ &= 32.5 \text{ V} \end{aligned}$$

Peak full-wave rectified voltage at the filter input

$$V_{ip} = 32.5 - 2 \times 0.7 = 31.1 \text{ V}$$

$$\begin{aligned} \gamma &= \frac{1}{4\sqrt{3}fCR_L} \\ &= \frac{1}{4\sqrt{3} \times 50 \times 5 \times 10^{-6} \times 20 \times 10^3} \\ &= 0.028 \text{ or } \mathbf{2.8\%} \end{aligned}$$

$$V_{dc} = \frac{V_{ip}}{1 + \frac{1}{4fCR_L}} = \frac{31.1}{1 + \frac{1}{4 \times 50 \times 5 \times 10^{-6} \times 20 \times 10^3}} = \mathbf{29.6 \text{ V}}$$

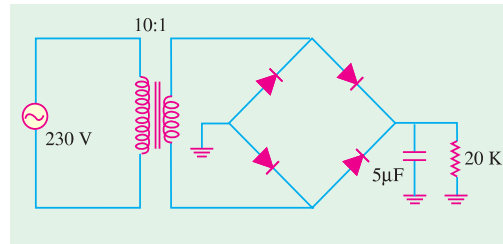

Fig. 55.23

Example 55.10. Derive an expression for the ripple in the output of a full-wave rectifier circuit, with a simple capacitor element as the filter.

The load current from the above circuit operating from 200-V, 50-Hz supply is 12 mA. Calculate minimum value of filter capacitor which is required to keep the ripple voltage below 2%.

(App. Electronics and Circuits ; Grad. I.E.T.E.)

Solution. As seen from Art. 5.17 $\gamma = I_{dc} / 4\sqrt{3}fCV_{ip}$

$$\therefore C = I_{dc} / 4\sqrt{3}f\gamma V_{ip} = 12 \times 10^{-3} / 4\sqrt{3} \times 50 \times 0.02 \times 200 = 6 \mu\text{F}$$

55.18. Series Inductor Filter

The filter consists of a choke in series with the load resistor R_L as shown in Fig. 52.24. The operation of such a filter depends on the fundamental property of an inductor to oppose any sudden changes in the current flowing through it. Since this inductor presents high impedance to the ac components in the filter output, it reduces their amplitude with respect to the dc component thereby producing only a small ripple as shown in Fig. 55.24 (b).

The Fourier series for the rectifier output voltage is

$$v_i = V_{ip} \left(\frac{2}{\pi} - \frac{4}{3\pi} \cos 2\omega t - \frac{4}{15\pi} \cos 4\omega t - \dots \right)$$

For finding the ripple factor, we will calculate the dc as well as ac drop over R_L . If we neglect choke resistance (R_C), then the entire dc component of filter output is available across R_L and its value is $V_{dc} = 2V_{ip}/\pi$ *.

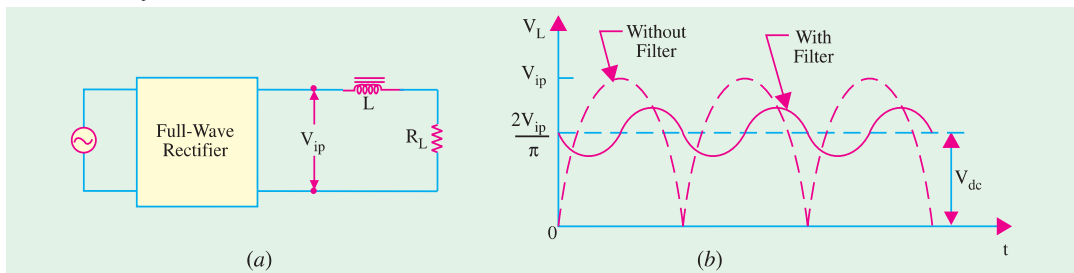

Fig. 55.24

* If R_C is taken into account, then filter output dc voltage drops partly on R_C and partly on R_L . The drop over R_L would be

$$= \frac{2V_{ip}}{\pi} \cdot \frac{R_L}{R_L + R_C}$$



We will consider only the second harmonic voltage $(4V_{ip}/3\pi) \cos 2\omega t$ of frequency 2ω and neglect higher harmonic voltages. This ac voltage partly drops over X_L and partly over R_L . Since choke and R_L are connected in series, the maximum value of drop over R_L is

$$= \frac{4V_{ip}}{3\pi} \cdot \frac{R_L}{\sqrt{R_L^2 + X_L^2}}$$

The rms value of this ac voltage drop across R_L is

$$V_{\alpha} = \frac{4V_{ip}}{\sqrt{2.3}\pi} \frac{R_L}{\sqrt{R_L^2 + X_L^2}}$$

$$\therefore \gamma = \frac{V_{\alpha}}{V_{dc}} = \frac{4V_{ip}}{\sqrt{2.3}\pi} \frac{R_L}{\sqrt{R_L^2 + X_L^2}} \times \frac{\pi}{2V_{ip}}$$

$$= \frac{\sqrt{2} R_L}{3\sqrt{(R_L^2 + X_L^2)}} = \frac{\sqrt{2}}{3\sqrt{1 + X_L^2 + R_L^2}^{1/2}}$$

Since

$$X_L = 2\omega L, \text{ hence } \gamma = \frac{\sqrt{2}}{3(1 + 4\omega^2 L^2 / R_L^2)^{1/2}}$$

$$\text{If } 4\omega^2 L^2 / R_L^2 \gg 1, \text{ then } \gamma = \frac{\sqrt{2}R_L}{3 \times 2\omega L} = \frac{R_L}{\sqrt{2.3}\omega L}$$

It is seen that ripple decreases as R_L decreases or load current increases (just the opposite of what happens in the case of shunt capacitor filter).

55.19. The Choke Input or L-C Filter

It is a combination of two filters considered in Art. 55.15 and 55.18 and provides a lower ripple than is possible with either L or C alone. As is known, in an inductor filter, ripple increases with R_L but decreases in a capacitor filter. The combination of L and C (*i.e.* L -section) filter makes the ripple independent of R_L . Fig. 55.25 (a) shows the filter and (b) the voltage variations.

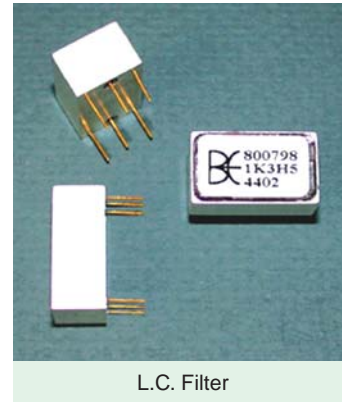

L.C. Filter

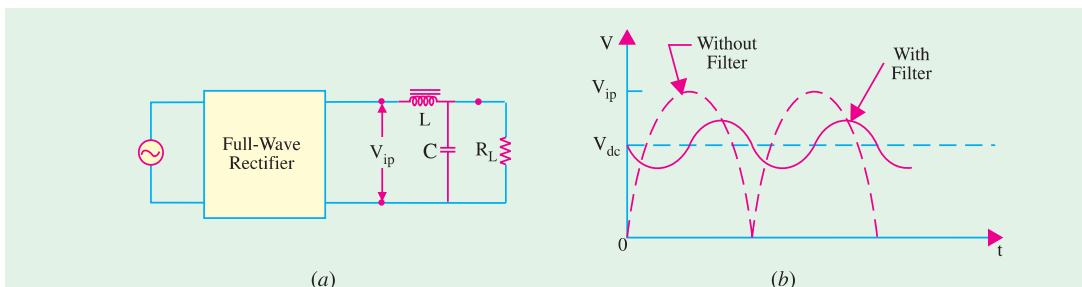

Fig. 55.25

Ripple Factor

If choke resistance R_C is neglected, then dc voltage available across $R_L = 2V_{ip}/\pi$. The ac drop over R_L is the same as across C . Since $X_C \ll R_L$, the parallel combination of R_L and X_C has impedance $\cong X_C$. The second harmonic voltage $(4V_{ip}/3\pi) \cos 2\omega t$ can be assumed to drop over the L - C series combination because R_L is effectively not there.

Maximum value of ac drop over C is



$$\begin{aligned}
 &= \frac{4 V_{ip}}{3 \pi} \cdot \frac{X_C}{(X_L + X_C)} \\
 \text{RMS value} &= \frac{4 V_{ip}}{\sqrt{2} \cdot 3 \pi} \cdot \frac{X_C}{(X_L + X_C)} \\
 \therefore \gamma &= \frac{V_{ac}}{V_{dc}} \frac{4 V_{ip}}{\sqrt{2} \cdot 3 \pi} \cdot \frac{X_C}{X_L + X_C} \times \frac{\pi}{2 V_{ip}} = \frac{\sqrt{2} X_C}{3 X_L} \text{---if } X_C \ll X_L \\
 &= \frac{\sqrt{2}}{3(2\omega C)(2\omega L)} = \frac{\sqrt{2}}{12\omega^2 LC} = \frac{1.19}{LC} \text{---if } C \text{ is in } \mu\text{F and } L \text{ in henrys}
 \end{aligned}$$

Now, $I_{dc} = 2V_{ip} / \pi RL$; maximum value of second harmonic current $I_{2h} = 4V_{ip} / 3\pi \times 2\omega L$. The critical (or minimum) value of choke inductance essential for proper working of the filter is reached when $I_{dc} = I_{2h}$ or $2V_{ip} / \pi RL = 4V_{ip} / 3\pi \cdot 2\omega L$ or $L = R_L / 3\omega$. For $f = 50$ Hz, $L = R_L / 940$.

Example 55.11. A single-phase full-wave rectifier uses 300-0-300 V, 50-Hz transformer. For a load current of 60 mA, design an L-filter using 10 H coil and a suitable capacitor to ensure a ripple factor of not more than 1%. (Electronics-II, Bangalore Univ.)

Solution.

$$\begin{aligned}
 \gamma &= 1.19/L \\
 0.01 &= 1.19/LC; \quad \therefore L_C = 119 \\
 \text{Hence, } 10 \times C &= 119 \\
 C &= 11.9 \mu\text{F} \approx 12 \mu\text{F}.
 \end{aligned}$$

55.20. The R-C Filter

Such a filter is shown in Fig. 55.26. Suppose that it is connected to a full-wave rectifier having a filtered output voltage of V_{ip} . The dc component voltage which drops over R_L is

$$= \frac{2 V_{ip}}{\pi} \cdot \frac{R_L}{R + R_L} \quad \dots (i)$$

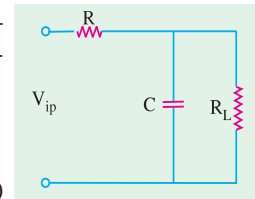

Fig. 55.26

Again, we would consider only the second harmonic voltage ($4 V_{ip} / 3\pi$) cos $2\omega t$. As before, it will be assumed that $X_C \ll R_L$ so that $R_L \parallel X_C \approx X_C$. In that case, ac voltage would be assumed to drop across R-C combination.

$$V_{ac} = \frac{1}{\sqrt{2}} \cdot \frac{4 V_{ip}}{3\pi} \cdot \frac{X_C}{\sqrt{R^2 + X_C^2}} = \frac{4 V_{ip}}{\sqrt{2} \cdot 3\pi} \cdot \frac{1}{\sqrt{1 + R^2 / X_C^2}}$$

Same is the drop across R_L .

$$\begin{aligned}
 \therefore \gamma &= \frac{V_{ac}}{V_{dc}} = \frac{4 V_{ip}}{\sqrt{2} \cdot 3\pi} \cdot \frac{1}{\sqrt{1 + R^2 / X_C^2}} \times \frac{\pi (R + R_L)}{2 V_{ip} \cdot R_L} \\
 &= \frac{\sqrt{2}}{3} \cdot \frac{1 + R/R_L}{\sqrt{1 + R^2 / X_C^2}} = \frac{(1 + R/R_L)}{3\sqrt{2} \omega CR} \quad \text{---if } R^2 / X_C^2 \gg 1
 \end{aligned}$$

55.21. The C-L-C or Pi Filter

As shown in Fig. 55.27, it consists of one inductor and two capacitors connected across its each end. The three components are arranged in the shape of the Greek letter π . It is also called capacitor input π -filter. The input capacitor C_1 is selected to offer very low reactance to the ripple frequency. Hence, major part of filtering is done by C_1 . Most of the remaining ripple is removed by the combined action of L and C_2 .

The charging and discharging action of C_1 is exactly the same as described in Art. 55.15. The output voltage waveform is also like that shown in Fig. 55.25 (b).



This circuit gives much better filtering than LC filter circuit. However, C_1 is still directly connected across the supply and would need high pulses of current if load current is large. Since these high peak current pulses are likely to damage the rectifier diode, this filter is used *with low-current equipment*.

Though this filter-gives somewhat higher output voltage, its voltage regulation is inferior to that of the LC filter.

The ripple factor of this filter is given by

$$\gamma = \sqrt{2} \frac{X_{C1} X_{C2}}{R_L X_L} = \frac{\sqrt{2}}{8\omega^3 C_1 C_2 L R_L} = \frac{5700}{L C_1 C_2 R_L} \quad \text{---when } f = 50 \text{ Hz}$$

Here, C_1, C_2 are in μF , L in henrys and R_L in ohms.

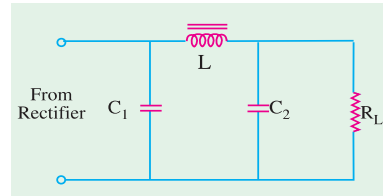

Fig. 55.27

55.22. Bleeder Resistor

Very often, a resistor (called bleeder resistor) is placed across the filter output (Fig. 55.28) because it provides the following advantages :

1. It improves voltage regulation of the supply. By acting as a pre-load on the supply, it causes an initial voltage drop. When the real load is connected, there is only a small amount of additional drop. In this way, difference between no-load and full-load voltage is reduced thereby improving the regulation.
2. It provides safety to the technicians handling the equipment. When power supply is switched off, it provides a path for the filter capacitor to discharge through. That is why it is called bleeder resistor. Without it, the capacitor will retain its charge for quite sometime even when the power supply is switched off. This high voltage can be dangerous for people working with the equipment.
3. By maintaining a minimum current through the choke, it improves its filtering action. Value of R_B should be such as to conduct 10 per cent of the total load current.

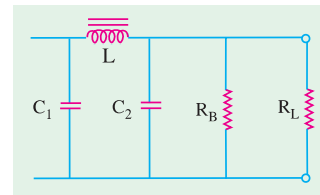

Fig. 55.28

55.23. Voltage Dividers

Often more than one dc voltage is needed for the operation of electronic circuits. A single power supply can provide as many voltages as are needed by using a voltage divider. As shown in Fig. 55.29 a voltage divider is a single tapped resistor connected across the output terminals of the supply. The tapped resistor may consist of two or three resistors connected in series across the supply. In fact, bleeder resistor may also be used as a voltage divider.

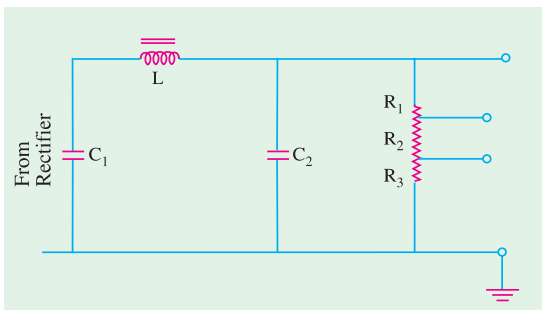
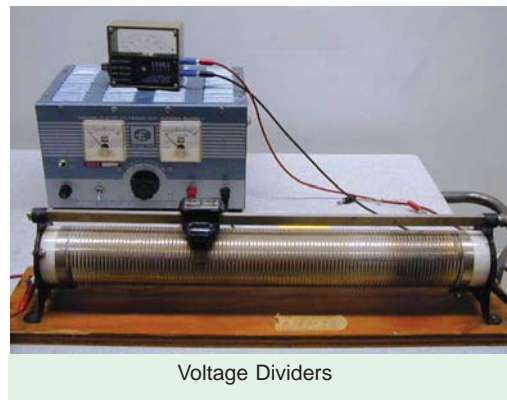

Fig. 55.29



Voltage Dividers



55.24. Complete Power Supply

Fig. 55.30 shows a complete solid-state power supply. From left to right, it consists of a transformer with a current-limiting resistor R_1 , rectifier diodes for full-wave rectification, a π -type filter, a transistor series voltage regulator and a voltage divider.

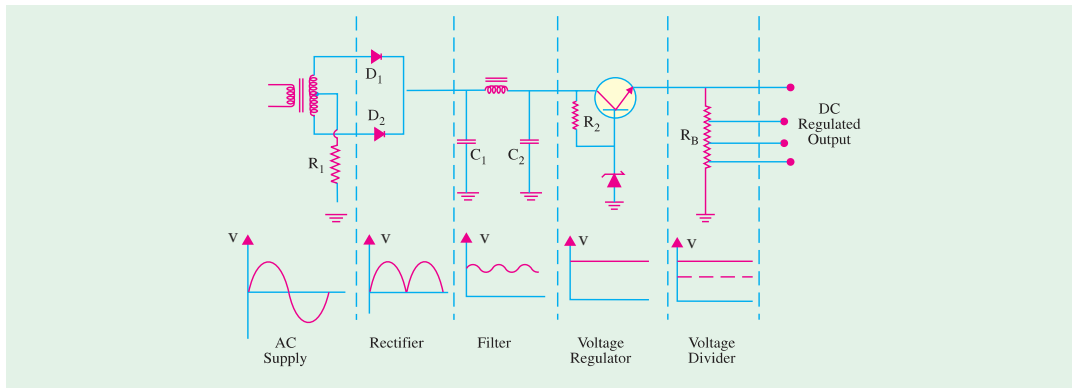

Fig. 55.30

As seen, unregulated ac voltage is fed from the transformer through a full-wave rectifier. It is then filtered by the CLC filter and finally regulated by a transistor regulator. The regulated dc supply becomes available across voltage divider resistance R_B . The output is practically ripple-free.

55.25. Voltage Multipliers

A voltage multiplier is a circuit which produces a greater dc output voltage than ac input voltage to the rectifiers. Multipliers are required in many circuit applications where it is necessary to have high voltages with low currents as for electron accelerating purposes in a cathode-ray tube (CRT).

We will consider the following circuit :

1. half-wave voltage doubler,
2. full-wave voltage doubler,
3. voltage tripler,
4. voltage quadrupler.

55.26. Half-wave Voltage Doubler

It is also known as cascade voltage doubler. The circuit is shown in Fig. 55.31.

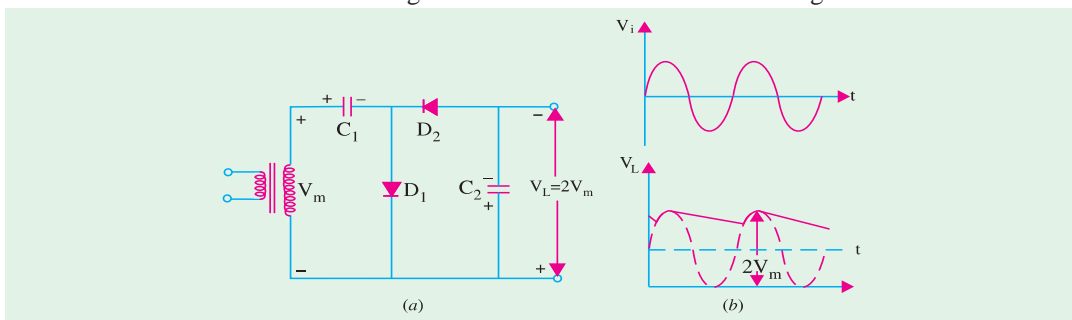

Fig. 55.31

Circuit Analysis

During the positive half-cycle of the input voltage, D_1 conducts (not D_2) and charges C_1 to peak value of secondary voltage (V_m) with the polarity as shown in Fig. 55.31 (a). During the negative half-cycle, D_2 conducts (not D_1) and charges C_2 . The voltage across C_2 is the sum of peak supply



voltage and the voltage across C_1 (Fig. 55.31). It can be proved by applying *KVL* to the outer loop. Starting from the bottom of the transformer secondary in Fig. 55.32 and going clockwise, we get

$$-V_m - V_m + V_{C_2} = 0$$

or $V_{C_2} = 2V_m = 2 \times \text{peak input voltage}$

During the next positive half-cycle, D_2 is open and C_2 will discharge through the load if it is connected. If no load is connected across C_2 , then both capacitors stay charged *i.e.* C_1 to V_m and C_2 to $2V_m$. If there is a load connected across C_2 , it will discharge a little bit and, as a result of it, voltage across it will drop slightly. But it will get recharged in the next half-cycle.

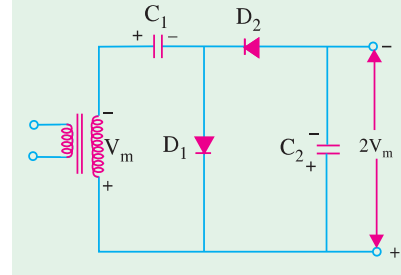

Fig. 55.32

The output waveform shown in Fig. 55.31 (b) is that of a half-wave rectifier filtered by a shunt capacitor. *PIV* across each diode is $2V_m$. Ripple frequency is equal to the supply frequency.

This circuit has very poor regulation and its ripple content is also high. This circuit has a common connection between the line and load (which a full-wave doubler does not have).

55.27. Full-wave Voltage Doubler

This circuit is shown in Fig. 55.33 (a). During the positive half-cycle of the input voltage, D_1 conducts (but not D_2) and charges capacitor C_1 to the peak voltage V_m with the polarity as shown.

During the negative half-cycle, D_2 conducts (but not D_1) charging C_2 to V_m . As far as the load is concerned, voltages across C_1 and C_2 are in series-aiding. If there is no load connected across the output, then load voltage $V_L = 2V_m$ as shown in Fig. 55.33 (a). For example, if 220-V, 50-Hz is the supply, then $V_{dc} = 2V_m = 2 \times \sqrt{2} = 620$ V. Of course, if a load is connected across the output terminals, then V_L would be less than $2V_m$.

The waveform of the output voltage is shown in Fig. 55.33 (b).

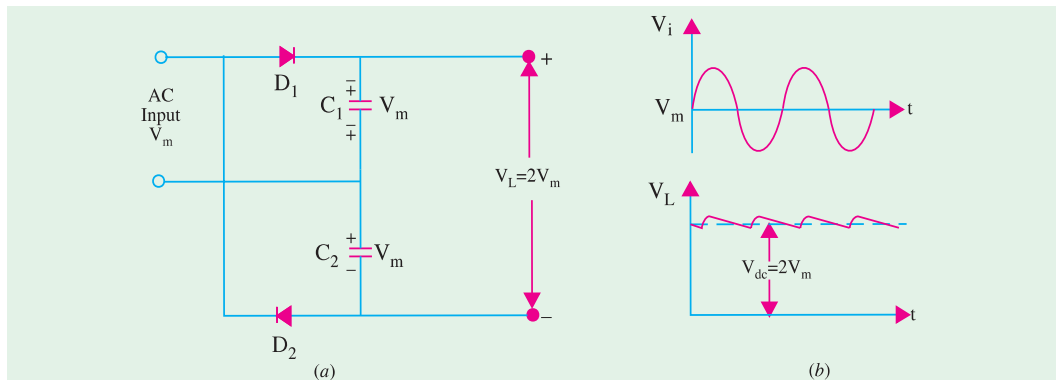

Fig. 55.33

The *PIV* rating of each diode is $2V_m$. Ripple frequency is twice the supply frequency. As seen, there is no common connection between the supply line and the load.

It is worth noting that where the expense of a line transformer is justified, it is preferable to use the superior conventional full-wave rectifier (Art. 55.7).

55.28. Voltage Tripler and Quadrupler Circuits

(a) General

The half-wave voltage doubler circuit (Fig. 55.31) can be extended to obtain any multiple of the peak input voltage (V_m) *i.e.* $3V_m, 4V_m, 5V_m$ etc. Theoretically speaking, there is no upper limit to the



amount of voltage multiplication that can be obtained. Though voltage triplers and quadruplers are commonly used, practical considerations limit additional multiplications. The main handicap is that total amount of capacitance becomes unduly large to maintain the desired dc output voltage for any thing except extremely light loads.

(b) Circuit

The circuit for different multipliers is shown in Fig. 55.34. It should be obvious from the repetitive pattern of the circuit connections how additional diodes and capacitors may be connected to the doubler circuit for obtaining higher multiplications of the peak output voltage V_m .

(c) Analysis

During the first positive half-cycle, C_1 charges to V_m as diode D_1 conducts. During negative half-cycle, C_2 is charged through D_2 to $2V_m$ i.e. to the sum of voltage across C_1 and peak input voltage V_m (Art 55.26).

During the second positive half-cycle, D_3 conduct and voltage across C_2^* charges C_3 to same voltage $2V_m$. During the negative half-cycle, diodes D_2 and D_4 conduct allowing C_3 to charge C_4 to the same peak voltage $2V_m$.

If it is seen from Fig. 55.34 that voltage across C_2 is $2V_m$, across C_1 and C_3 is $3V_m$ and across C_2 and C_4 is $4V_m$.

If additional diodes and capacitors are used, each capacitor would be charged to a peak voltage of $2V_m$.

The *PIV* rating of each diode is $2V_m$ and ripple frequency is twice the line frequency. Generally, these circuits are used where both the supply voltage and load are maintained constant.

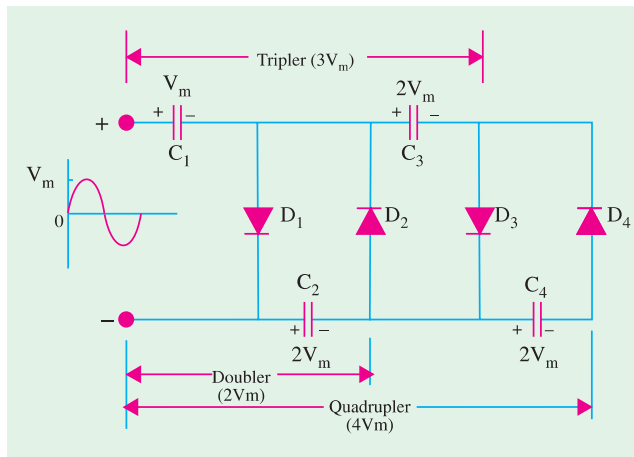

Fig. 55.34

55.29. Troubleshooting Power Supplies

There are usually two types of problems with power supplies i.e. either no dc output or low dc output.

The situation of no dc output can occur due to any one of the following reasons :

1. when there is no output from the rectifiers,
2. when there is no ac input to power supply,
3. when filter choke is open,
4. when the first input capacitor shorts.

A low dc output can occur in the following situations :

1. decreased input ac voltage,
2. open input capacitor of the filter circuit,
3. partial short across the load.

55.30. Controlled Rectification

It is that rectification in which the output of a rectifier circuit can be varied by controlling the point in the ac cycle at which the circuit is turned ON. A thyristor or *SCR* can be used for the purpose

* C_1 cannot charge C_3 because it is shorted by D_1 .



because under proper firing conditions, it can control the conduction angle of the rectifier circuit.

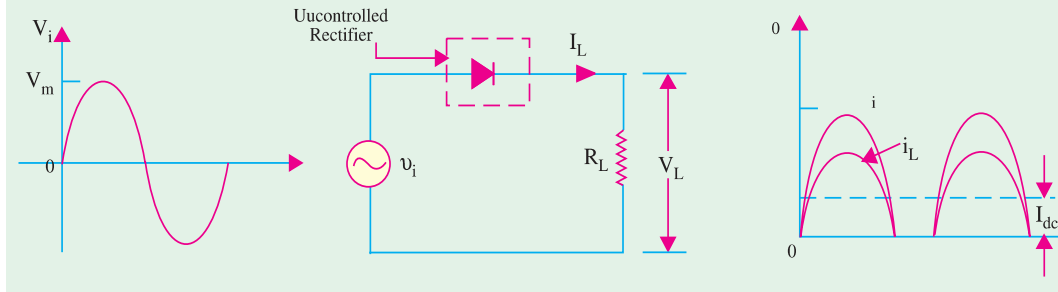

Fig. 55.35

In an ordinary diode rectifier circuit, current flows through the diode whenever instantaneous value of the ac supply voltage is greater than the voltage across the load at that instant.

For a resistive load shown in Fig. 55.35, load current flows at all times during the positive half-cycles of the supply.

In a controlled rectifier, on the other hand, load current flows only when a control signal is applied to turn on the rectifier at a specific point [like A in Fig. 55.36 (b)] in the ac cycle. Point A corresponds to the angle θ_1 so that conduction is delayed by this much period.

Once the HW rectifier is turned ON, it remains in conduction for the rest of the positive half-cycle *i.e.* upto 180° . Obviously, the firing point A is determined by the angle of delay in a plying the firing signal by the control circuit. As θ_1 increases, conduction occurs later in the cycle thereby decreasing the load current further.

The curve for voltage drop across rectifier diode is shown in Fig. 55.36 (c). During the positive half-cycle when the rectifier is fired into conduction, it acts like a short and voltage across it drops to zero (neglecting forward voltage of the diode). During negative half-cycle when diode is reverse-biased (and hence open) the full supply voltage appears across it as shown.

The curve for load voltage is shown in Fig. 55.36 (d). Since current obeys Ohm's law, it follows the load voltage.

Average Value of Load Voltage

Let the equation of the supply voltage be $V_i = V_m \sin \theta$

For a half-wave rectifier, average value is found by taking average over the whole cycle (2π) even though conduction takes

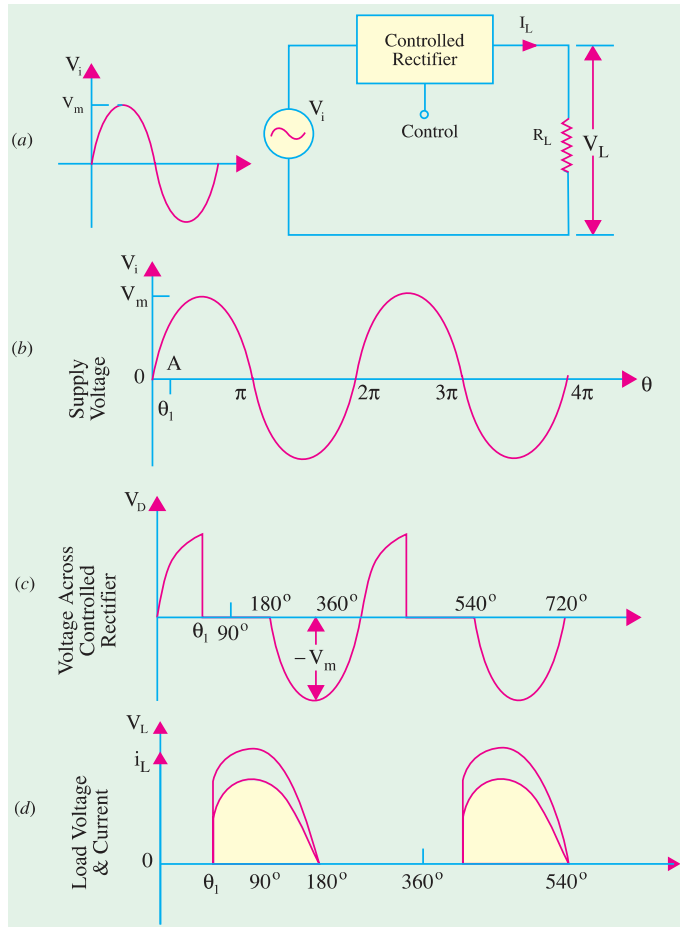

Fig. 55.36



place only from $\theta_1 - \pi$ in the entire cycle.

$$\begin{aligned} \therefore V_L &= \frac{1}{2\pi} \int_{\theta_1}^{\pi} V_i d\theta \\ &= \frac{1}{2\pi} \int_{\theta_1}^{\pi} V_m \sin \theta d\theta \\ &= \frac{V_m}{2\pi} \int_{\theta_1}^{\pi} \sin \theta d\theta \\ &= \frac{V_m}{2\pi} [-\cos \theta]_{\theta_1}^{\pi} \\ &= \frac{V_m}{2\pi} |(-\cos \pi) - (-\cos \theta_1)| \\ &= \frac{V_m}{2\pi} (1 + \cos \theta_1) \\ \therefore V_{dc} = V_L &= \frac{V_m}{2\pi} (1 + \cos \theta_1) \end{aligned}$$

For a resistive load,

$$I_{dc} = I_L = \frac{V_m}{2\pi R_L} (1 + \cos \theta_1)$$

Note : If

$$\begin{aligned} \theta_1 &= 0, \text{ then } V_{dc} \\ &= \frac{V_m}{\pi} \text{ and } I_{dc} = \frac{V_m}{\pi R_L} \end{aligned}$$

These are the same values as for an uncontrolled or ordinary HW rectifier (Art 55.6).

55.31. Output Waveforms for Different Firing Angles

In all waveforms given in Fig. 55.37 it has been assumed that the ac supply voltage is sinusoidal given by the equation $V_i = V_m \sin \theta$. Also, a resistive load has been assumed.

Following points must always be kept in mind while drawing these diagrams. When the diode is forward-biased, it conducts and behaves like a short. Hence, drop across it is almost zero. Instead, whole of the applied voltage drops across load resistance. When during the negative input half-cycle, diode is reverse-biased, it does not conduct and behaves like an 'open'. Hence, all the applied voltage appears across the rectifier diode and none across R_L . In other words, diode anode voltage and load voltage are mutually exclusive *i.e. when one is there, the other is not.*

It is seen from Fig. 55.38 that as delay angle θ_1 is increased, the output keeps decreasing till for $\theta_1 = 180^\circ$, *the output is zero.*

55.32. Output Voltage and Current Values in Controlled Rectifiers

We will use the equation derived in Art 55.30 for a half-wave rectifier *i.e.*

$$\begin{aligned} V_{dc} &= \frac{V_m}{2\pi} (1 + \cos \theta_1) \\ I_{dc} &= \frac{V_m}{2\pi R_L} (1 + \cos \theta_1) = \frac{V_{dc}}{R_L} \end{aligned}$$



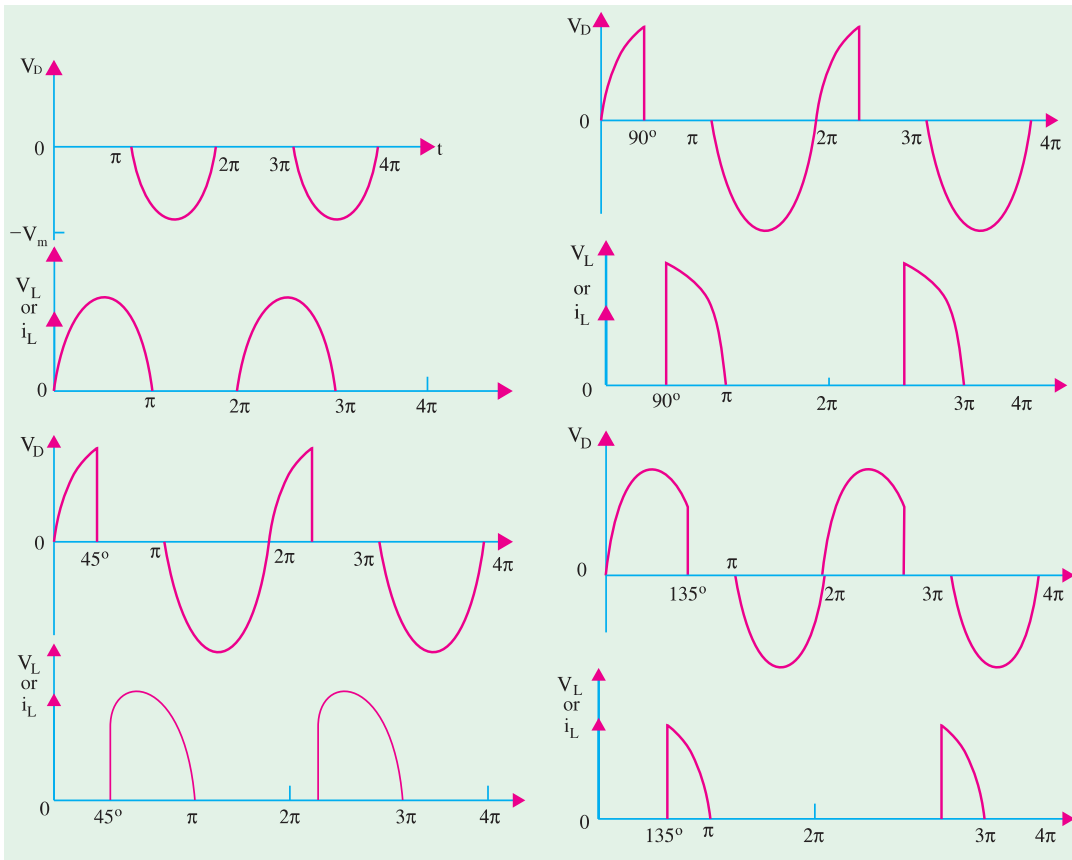

Fig. 55.37

Fig. 55.38

(a) when $\theta_1 = 0$

$$\begin{aligned} \cos \theta_1 &= \cos 0^\circ = 1 \\ V_{dc} &= \frac{V_m}{2\pi} (1 + 1) = \frac{V_m}{\pi} = 0.318 V_m \\ I_{dc} &= \frac{V_{dc}}{R_L} = \frac{V_m}{\pi R_L} = 0.318 \frac{V_m}{R_L} \end{aligned}$$

(b) when $\theta_1 = 30^\circ$

$$\begin{aligned} \cos \theta_1 &= \cos 30^\circ = 0.866 \\ \therefore V_{dc} &= \frac{V_m}{2\pi} (1 + 0.866) = 0.297 V_m ; I_{dc} = \frac{V_{dc}}{R_L} = 0.297 \frac{V_m}{R_L} \end{aligned}$$

(c) when $\theta_1 = 45^\circ$

$$\begin{aligned} \cos \theta_1 &= \cos 45^\circ = 0.707 \\ \therefore V_{dc} &= \frac{V_m}{2\pi} (1 + 0.707) = 0.27 V_m ; I_{dc} = \frac{V_{dc}}{R_L} = 0.27 \frac{V_m}{R_L} \end{aligned}$$

(d) when $\theta_1 = 60^\circ$

$$\begin{aligned} \cos \theta_1 &= \cos 60^\circ = 0.5 \\ \therefore V_{dc} &= \frac{V_m}{2\pi} (1 + 0.5) = 0.239 V_m ; I_{dc} = \frac{V_{dc}}{R_L} = 0.239 \frac{V_m}{R_L} \end{aligned}$$



(e) when $\theta_1 = 90^\circ$

$$\begin{aligned}\cos \theta_1 &= \cos 90^\circ = 0 \\ V_{dc} &= \frac{V_m}{2\pi} (1 + 0) = \frac{V_m}{2\pi} = 0.159 V_m \\ I_{dc} &= \frac{V_{dc}}{R_L} = \frac{V_m}{2\pi R_L} = 0.159 \frac{V_m}{R_L}\end{aligned}$$

(f) when $\theta_1 = 120^\circ$

$$\begin{aligned}\cos \theta_1 &= \cos 120^\circ = -0.5 \\ \therefore V_{dc} &= \frac{V_m}{2\pi} (1 - 10.5) = 0.08 V_m ; I_{dc} = \frac{V_{dc}}{R_L} = 0.08 \frac{V_m}{R_L}\end{aligned}$$

(g) when $\theta_1 = 135^\circ$

$$\begin{aligned}\cos \theta_1 &= \cos 135^\circ = -0.707 \\ V_{dc} &= \frac{V_m}{2\pi} (1 - 0.797) = 0.0466 V_m ; I_{dc} = 0.0466 \frac{V_m}{R_L}\end{aligned}$$

Example 55.12. A $100\text{-}\Omega$ load is connected to a peak supply of 300 V through a controlled half-wave diode rectifier. The load power is to be varied from 25 W to 80 W . What is the angular firing control required? Neglect forward drop of the diode. **(Basic Electronics, Pune Univ. 1990)**

Solution.

$$P = V_{dc} \cdot I_{dc}$$

$$\text{Now, } V_{dc} = \frac{V_m}{2\pi} (1 + \cos \theta), \quad I_{dc} = \frac{V_m}{2\pi R_L} (1 + \cos \theta)$$

$$\begin{aligned}\therefore P &= \left(\frac{V_m}{2\pi}\right)^2 \cdot \frac{1}{R_L} (1 + \cos \theta)^2 = \left(\frac{300}{2\pi}\right)^2 \cdot \frac{1}{100} (1 + \cos \theta)^2 \\ &= 22.5 (1 + \cos \theta)^2\end{aligned}$$

(i) when $P = 80\text{ W}$

$$\begin{aligned}\therefore 80 &= 22.5 (1 + \cos \theta)^2 \quad \text{or } (1 + \cos \theta) = 1.8856 \\ \therefore \cos \theta &= 0.8856 \quad \text{or } \theta = 27.7^\circ\end{aligned}$$

(ii) when $P = 25\text{ W}$

$$\therefore 25 = 22.5 (1 + \cos \theta)^2 \quad \therefore \cos \theta = 0.1111 \quad \text{or } \theta = 83.6^\circ$$

Example 55.13. In a controlled half-wave rectifier, peak supply voltage is 200 V and the value of load resistor is $1\text{ k}\Omega$. Calculate the power delivered to the load circuit for firing angles of (i) 0° (ii) 45° (iii) 90° and (iv) 135° . **(Solid State Devices and Ckts, BHU)**

$$\begin{aligned}\text{Solution. (i) } V_{dc} &= 0.318 \times 200 = 63.6\text{ V} ; & I_{dc} &= 63.6/1000 = 63.6\text{ mA} \\ P &= V_{dc} \cdot I_{dc} = 63.6 \times 63.6 & &= 4045\text{ mW} = \mathbf{4.045\text{ W}}\end{aligned}$$

$$\begin{aligned}\text{(ii) } V_{dc} &= 0.27 \times 200 = 54\text{ V} ; & I_{dc} &= 54/1000 = 54\text{ mA} \\ P &= 54 \times 54 = 2916\text{ mW} & &= \mathbf{2.916\text{ W}}\end{aligned}$$

$$\begin{aligned}\text{(iii) } V_{dc} &= 0.159 \times 200 = 31.8\text{ V} ; & I_{dc} &= 31.8\text{ mA} \\ P &= 31.8 \times 31.8 = 1011\text{ mW} & &= \mathbf{1.011\text{ W}}\end{aligned}$$

$$\begin{aligned}\text{(iv) } V_{dc} &= 0.0466 \times 200 = 9.3\text{ V} ; & I_{dc} &= 9.3\text{ mA} \\ P &= 9.3 \times 9.3 = 86.5\text{ mW} & &= \mathbf{0.0865\text{ W}}\end{aligned}$$

55.33. Average Values for FW Controlled Rectifier

In this case, the average values would be doubled because there are two half sinusoids to be averaged as shown in Fig. 55.39 for $\theta_1 = 60^\circ$.



$$V_{dc} = 2 \times \frac{V_m}{2\pi} (1 + \cos \theta_1) = \frac{V_m}{\pi} (1 + \cos \theta_1)$$

$$\left[I_{dc} = \frac{V_{dc}}{R_L} = \frac{V_m}{\pi R_L} (1 + \cos \theta_1) \right]$$

In the present case, $\theta_1 = 60^\circ$, $\cos \theta_1 = 0.5$

$$\therefore V_{dc} = \frac{V_m}{\pi} (1 + 0.5) = 0.477 V_m$$

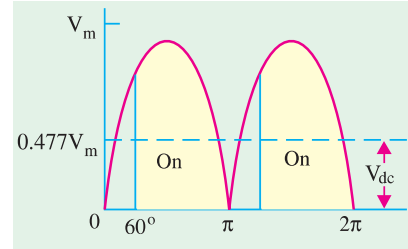

Fig. 55.39

55.34. Silicon Controlled Rectifier (SCR)

It is a trijunction PNPN device having three external connections : anode (A), cathode (C) and gate (G) as shown in Fig. 55.40.

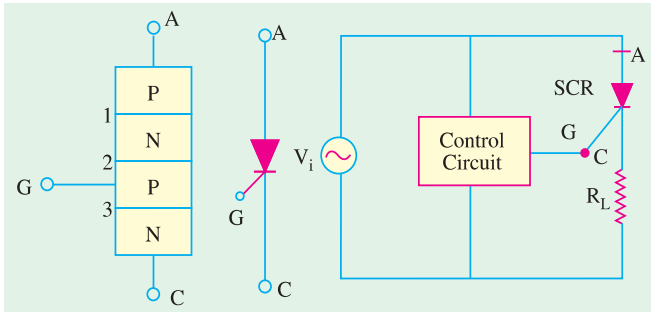

Fig. 55.40

When A is made positive with respect to C, the junctions marked 1 and 3 are forward-biased but the centremost junction marked 2 is reverse-biased. Hence, the SCR does not conduct. However, if a sufficiently positive voltage pulse is applied to this junction via the gate G, the SCR starts conducting like an ordinary diode. Gate has no control over SCR once it has been triggered into conduction. Conduction can only be terminated by removing positive voltage from its anode.

As shown in Fig. 55.40 (b), SCR needs a control circuit which triggers it into conduction by a gate pulse. Two popular ways of turning ON an SCR are:

1. Amplitude firing—in which gate current flows for the whole period of conduction.
2. UJT oscillator firing—in this method, gate current is supplied only momentarily. This method allows control over the power delivered to SCR's load from zero watt to fully ON.

Some of the simple ways of controlling the conduction of an SCR are discussed below.

55.35. Pulse Control of SCR

The simplest SCR control circuit of this type is shown in Fig. 55.41. If SCR were an ordinary rectifier, it would produce half-wave rectified ac voltage across R_L . However, SCR will not conduct even during positive half-cycle of the input ac voltage unless G is given positive voltage to forward-bias its centremost junction. By applying a trigger pulse at any time during the positive input half-cycle, it can be fired into conduction.

The resultant load waveform across R_L will consist of a portion of the positive half-cycle commencing at the instant at which the SCR is triggered [Fig. 55.41 (c)].



SCR and diode tester



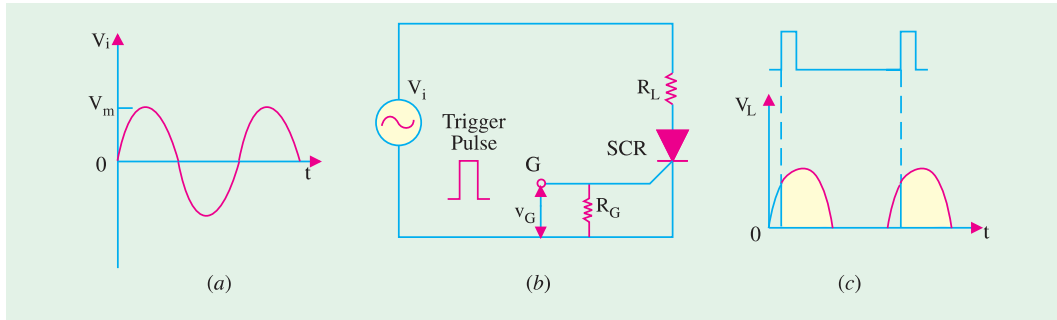

Fig. 55.41

55.36. 90° Phase Control of SCR

Fig. 55.42 shows a circuit which can trigger (or switch on) SCR any where from the commencement of the ac cycle to the peak of its positive half-cycle *i.e.* between 0° and 90°. As shown, gate current is derived from the ac supply (often it is from rectifier output as in Fig. 5.44) *via* R. If R is set at low value, the SCR will trigger almost at the commencement of the positive half-cycle of the ac input. On the other hand, if R is set at high resistance, the SCR may not switch ON until the peak positive half-cycle when sufficiently large gate current would become available.

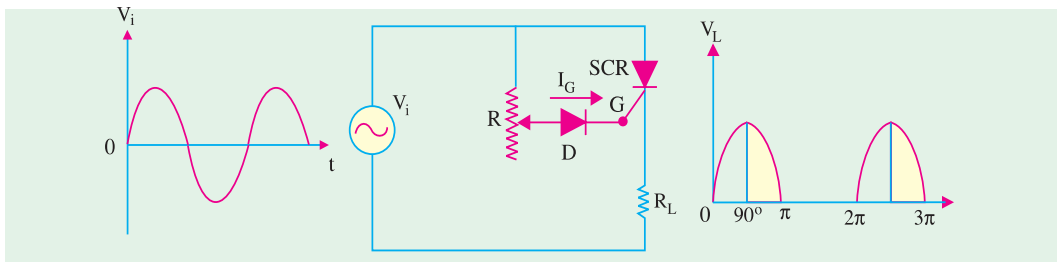

Fig. 55.42

If I_G is not large enough even at peak positive half-cycle, then SCR will not trigger at all because I_G has the greatest value at the peak input and then falls off as the voltage falls. The purpose of diode D is to protect the SCR gate from negative voltage during the negative input half-cycle. This method is also known as the amplitude firing of an SCR.

55.37. 180° Phase Control of SCR

The circuit shown in Fig. 55.43 can trigger the SCR from 0° to 180° of the input waveform.

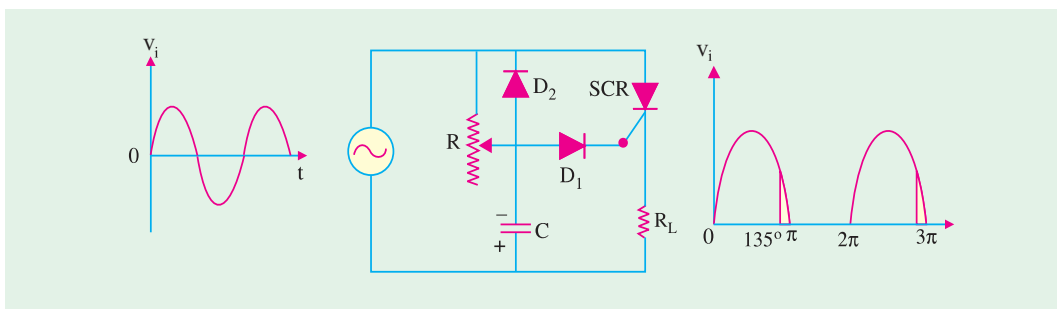

Fig. 55.43

The circuit is identical to that of Fig. 55.42 except for the addition of the diode D_2 and capacitor C.



We will start the analysis with the negative half-cycle. During the negative half-cycle of the input, C is charged immediately (with the polarity as shown) to the peak of the input voltage because D_2 is forward-biased. When peak of the negative half-cycle passes over, D_2 becomes reverse-biased because its anode (connected to C) becomes more negative than its cathode (connected to the supply). Hence, C starts to discharge through R . Depending on the time constant ($= CR$), C may almost be completely discharged at the commencement of the oncoming positive half-cycle or may retain partial charge until almost 180° of positive half-cycle has passed. So long as C remains negatively-charged, D_1 is reverse-biased and the gate cannot become positive to trigger the SCR into conduction. Hence, R and/or C can be adjusted to trigger the SCR anywhere from 0° to 180° of the input ac cycle.

55.38. SCR Controlled Load Circuit

We will now consider a circuit where an amplitude-fired SCR is used to control the power in a full-wave rectifier circuit.

In Fig. 55.44, R_L is the load resistance which may be a lamp load, heater or a small dc motor whose power we wish to control. The full-wave bridge rectifier furnishes the rectified output shown in Fig 55.45 (a). Obviously, control over both half-cycles of the ac input is possible.

The rectifier output voltage is dropped across the potentiometer AA . When potentiometer is set at point 1, drop across R_3 is not enough to provide sufficient gate current to switch ON the SCR . Hence, there is no load current and, consequently, no drop across the load. When potentiometer is set at point 2 and then 3, the SCR gets fired yielding load voltage waveforms shown in Fig. 55.45 (b) and (c). Hence, changing the conduction angle and hence the amount of power delivered to the load.

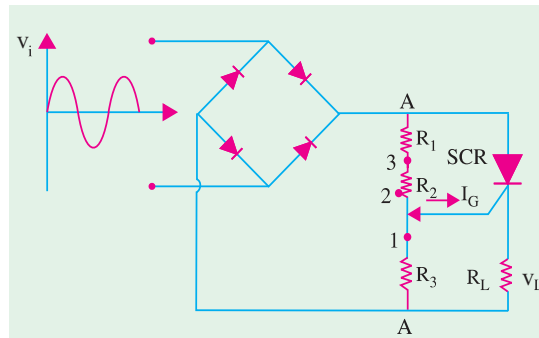

Fig. 55.44

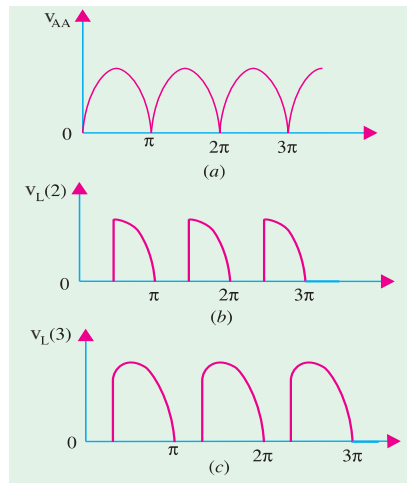

Fig. 55.45

55.39. UJT Controlled Load Circuit

This circuit employs a UJT oscillator to control the firing of the SCR as shown in Fig. 55.46. The full-wave rectified output voltage VAF is available across two parallel paths AF and BF . When SCR is not conducting (*i.e.* it acts as an open), then whole output voltage drops across it and none across R_L . When it conducts (*i.e.* acts as a short), whole of VAF drops across R_L and none across it.

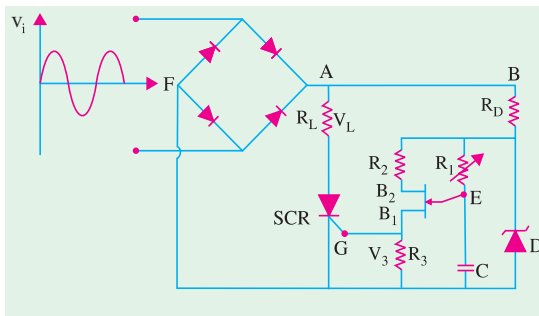

Fig. 55.46

Now, consider the other parallel circuit BF . R_D is the voltage dropping resistor so that a suitable voltage V_U is applied to the UJT oscillator circuit for the UJT to work without damage. The full-wave rectified voltage is clipped at a convenient level by Zener diode D for proper operation of UJT . Varying R_1 varies the time it takes for C to charge to the UJT 's firing voltage. Charging of C always starts when V_U is at 0 V dc or at 0° of V_{AF} .

If R_1 is very small, C charges very quickly (\because time constant CR_1 is very short) and reaches the



UJT firing voltage soon after V_{AF} starts to go positive. Hence, *UJT* fires early on every cycle of V_{AF} . When *UJT* fires, it becomes almost a short between its emitter (E) and B_1 . Thus, it discharges C very quickly through R_3 which is in parallel with the *SCR*'s gate. This triggers the *SCR* early in the cycle of V_{AF} and the *SCR* latches itself ON until V_{AF} falls to zero. When V_{AF} goes to zero, the *SCR* is shut OFF. The cycle repeats itself with the *SCR* being turned ON early in the cycle thereby delivering nearly full-power to the load.

When R_1 is increased, V_C rises slowly and reaches the *UJT* firing voltage later during each cycle of V_{AF} . Therefore, *SCR* is turned ON much later thereby considerably cutting down the power delivered to the load as shown in Fig. 55.47. Obviously, the *SCR* is being fired during the last few degrees of the cycle.

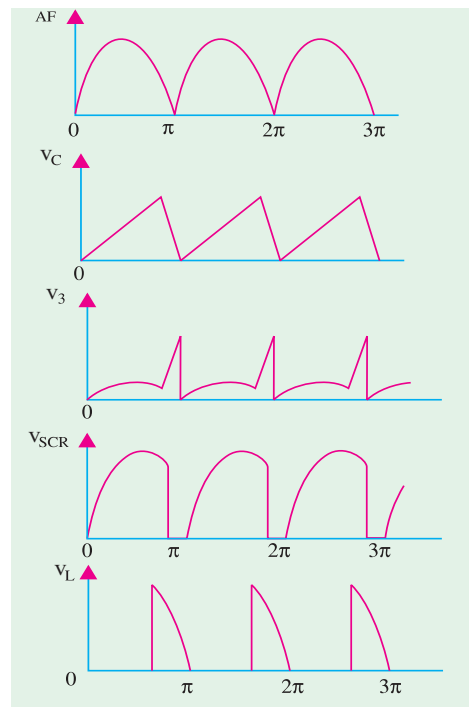

Fig. 55.47

55.40 Chopper

(a) Definition

To put it simply, a chopper is a **dc-to-dc converter**. It converts a given constant dc voltage into a variable average dc voltage across a load by placing a high-speed static switch between the dc source and the load. This high-speed static switch is called a chopper because it chops off the dc supply into ON and OFF periods of flow.

(b) Basic Circuit

A basic chopper circuit is shown in Fig. 55.48. When switch S is closed, the dc supply voltage V_{dc} is applied across the load and when it is open, the load is disconnected from the supply. By varying the ratio of the switch-closed time (T_{ON}) to the switch-open time (T_{OFF}) at a fixed frequency, the value of the average output dc voltage can be controlled.

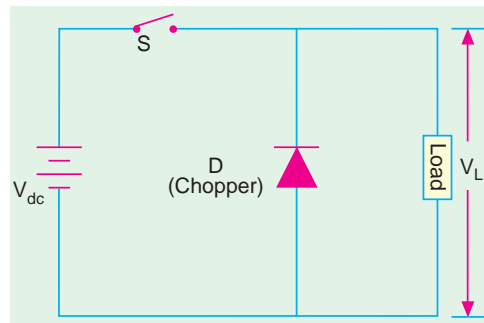

Fig. 55.48

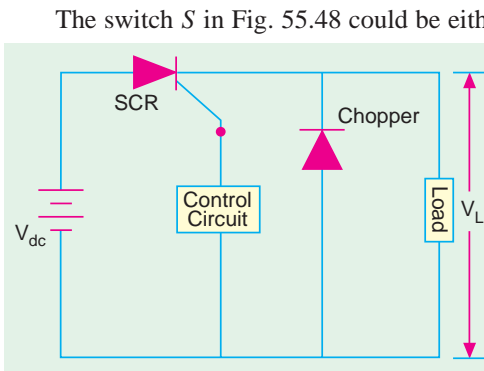

Fig. 55.49

The switch S in Fig. 55.48 could be either a transistor or an *SCR* depending on the amount of power involved. An *SCR* is used in high-power applications whereas transistors are used when power involved is low. A dc chopper circuit using an *SCR* is shown in Fig. 55.49. The *SCR* acts like a static switch and has two states of ON and OFF. The duration of ON and OFF states can be varied with the help of triggering and commutating circuits (not shown) respectively. By changing the values of ON and OFF periods, average dc load voltage can be changed.

(c) Working

When *SCR* is triggered into conduction with the help of control circuitry, full dc voltage V_{dc} is applied across



the load for a period of T_{ON} . When the SCR is switched OFF by the control circuitry, there is no voltage across the load. The output load voltage is in the form of a square wave as shown in Fig. 55.50. The waveshapes of the load current and chopper current for an inductive load are as shown. The freewheeling diode D provides path for the stored inductive energy to flow.

(d) Calculations

If T_{ON} is the ON time and T_{OFF} is the OFF time of the chopper, the duty cycle of the chopper is given by

$$\text{duty cycle} = \frac{T_{ON}}{T} = \frac{T_{ON}}{T_{ON} + T_{OFF}}$$

The load voltage V_L is given by

$$V_L = V_{dc} \left(\frac{T_{ON}}{T} \right) = V_{dc} \times \text{duty cycle} = f V_{dc} T_{ON}$$

where $f (= 1/T)$ is the switching frequency of the chopper.

It is seen from the above that V_L depends on the duty cycle since V_{dc} is constant. Hence, following different methods of controlling V_L are available.

1. keeping T_{OFF} constant, varying T_{ON} ;
2. keeping T_{ON} constant, varying T_{OFF} ;
3. varying the ratio T_{ON}/T_{OFF} ;
4. any combination of the above.

Example 55.14. A dc chopper has ON time of $30 \mu\text{s}$ and OFF time of $10 \mu\text{s}$. Calculate (i) chopper duty cycle, (ii) chopping frequency.

Solution. (i) duty cycle = $T_{ON}/T = 30/(30 + 10) = 0.75$
 (ii) chopping frequency, $f = 1/T = 1/(30 + 10) \times 10^{-6}$
 $= 25,000 \text{ Hz} = 25 \text{ kHz}$

Example 55.15. A chopper supplied by a 200 V dc has ON time of 30 ms and OFF time of 10 ms. Determine the value of the average dc output voltage.

(Industrial Electronics, Mysore Univ. 1993)

Solution. $T_{ON} = 30 \times 10^{-3} \text{ s}$, $T_{OFF} = 10 \times 10^{-3} \text{ s}$,
 $T = 40 \times 10^{-3} \text{ s}$
 Duty cycle of the chopper = $30 \times 10^{-3} / 40 \times 10^{-3} = 0.75$
 $V_L = V_{dc} \times \text{duty cycle} = 200 \times 0.75 = 150 \text{ V}$

55.41. Inverters

An inverter is a device that **changes dc power into ac power** (just the opposite of converters). The inversion process can be achieved with the help of transistors, SCRs and tunnel diodes etc. For low and medium outputs, transistorised inverters are suitable but for high power outputs, SCR inverters are essential. For very low voltage and high current requirements, tunnel diode inverters are used.

For inverter applications, transistors have definite advantages over SCRs regarding the switching speed, simplicity of control circuitry, high efficiency and greater reliability. It is mainly due to this fact the SCR inverters require

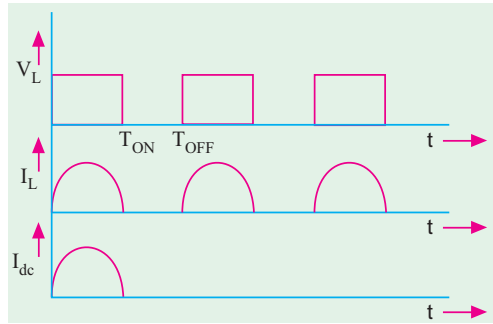

Fig. 55.50



Power Inverter



complicated circuitry for triggering and commutation.

The basic working principle of an inverter may be explained with the help of circuit shown in Fig. 55.51. It is called voltage-driven inverter because a dc voltage source is connected through semiconductor switches directly to the primary of a transformer.

In Fig. 55.51, S_1 and S_2 are switching devices (transistors or SCRs) which open and close alternately at regular intervals of time. The two switching devices are generally driven by an astable multi-vibrator operating at the desired frequency.

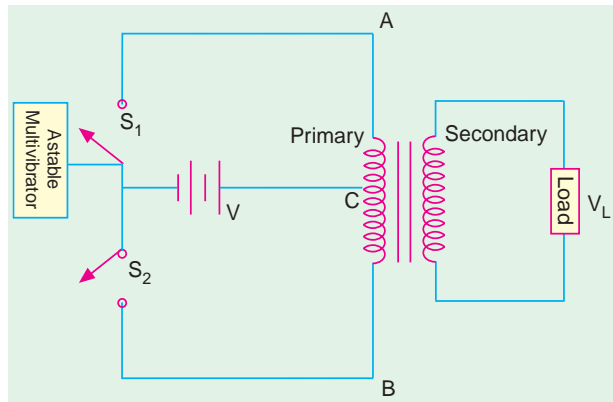

Fig. 55.51

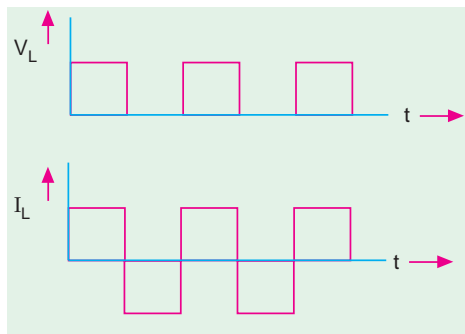

Fig. 55.52

When S_1 is closed, the entire dc source voltage V is applied across points A and B of the transformer primary. S_1 remains closed for a certain period of time after which it is cut off and S_2 closes. It also remains closed for the same period of time during which the source voltage V is impressed across points B and C of the primary. S_2 then opens out and S_1 closes. In this way, an alternating voltage is applied across the primary which induces an ac voltage in the secondary. Since dc supply voltage is connected directly across the primary, the output waveform of the secondary voltage is a square wave (Fig. 55.52) irrespective of the type of load and load power factor. However, the waveforms of both the primary and secondary currents depend on the type of load whether resistive, inductive or capacitive.

55.42. Single-phase Inverter

Fig. 55.53 (a) shows a single-phase inverter with a load resistor using 4 SCRs working in pairs. The triggering and commutating circuitry of the SCRs has not been shown in the figure. The two thyristors SCR_1 and SCR_4 are triggered simultaneously so that load current passes through R_L from left to right. Exactly when these two SCRs are switched off by the commutating circuitry, thyristors SCR_2 and SCR_3 are triggered into conduction

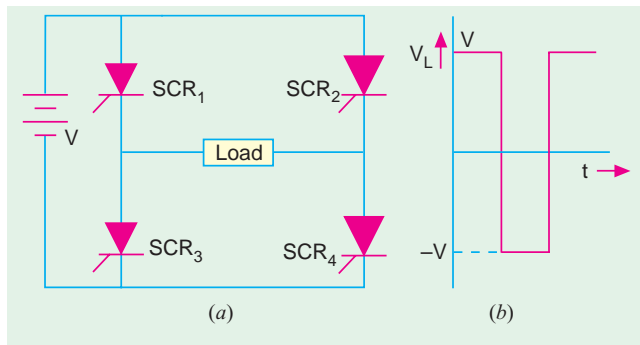

Fig. 55.53



Single-phase inverter

thereby sending current through R_L from right to left. Hence, an ac voltage is developed across the load whose waveform is as shown in Fig. 55.53 (b).

55.43. Push pull Inverter

Fig. 55.54 shows an inverter which



employs two SCRs and one transformer. These two SCRs are triggered into conduction alternately for the same period of time. As a result, current through the primary becomes alternating which induces an ac voltage across the secondary and hence the load. As explained earlier in Art 55.42, the secondary ac voltage has a square waveform. The capacitor C is connected across the anodes of the two SCRs and provides commutation *i.e.* switching off of the SCRs. The capacitor charges to double the supply voltage as a result of transformer action between the two halves of the primary winding. This large voltage is sufficient to reverse-bias the SCRs and drive the holding current below its rated value.

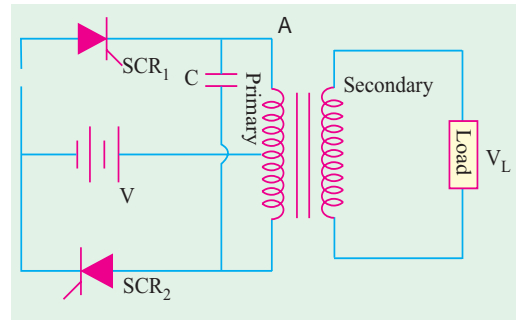

Fig. 55.54

Tutorial Problems No. 55.1

- A 1- ϕ half-wave rectifier using a 10 : 1 transformer supplies power to a $9\ \Omega$ load. If the primary input voltage has an r.m.s. value of 200 V and forward diode resistance is $0.2\ \Omega$ and transformer secondary resistance is $0.8\ \Omega$, determine
 (i) $I_L(dc)$, (ii) r.m.s. ripple voltage and (iii) efficiency [(i) 0.9 A (ii) 9.8 V (iii) 36.54%]
- A single-phase full-wave rectifier using a power transformer has secondary voltage of 100-0-100V (r.m.s.). It supplies a load of 1 K. Neglecting transformer losses and forward voltage drop of the diode, determine :
 (a) dc output voltage, (b) dc output current, (c) ripple voltage and PIV rating of the diodes.
 [(a) 90 V (b) 90 mA (c) 43.4 V (rms.) ; 282 V]
- A single-phase half-wave rectifier supplies power to a 1 K load. The rectifier voltage is 200 V (r.m.s.). Neglecting diode resistance, calculate (i) dc load voltage, (ii) dc load current and (iii) r.m.s. ripple voltage.
 [(i) 90 V (ii) 90 mA (iii) 1.09 V]
- A single-phase half-wave diode rectifier supplies power to a 2-k Ω resistive load. The input ac supply voltage has a peak value of 300 V. Neglecting forward drop of the diode, calculate
 (a) V_{dc} , (b) I_{dc} , (c) power delivered to the load, (d) ripple voltage (rms value)
 [(a) 95.4 V (b) 47.7 mA (c) 4550 mW (d) 115.4 V]
- A full-wave diode rectifier supplies a load of 10 k Ω . The ac voltage applied to the diode is 300-0-300 V rms. Its diode resistance is neglected, calculate: (a) V_{dc} , (b) I_{dc} , (c) I_{rms} , (d) form factor, (e) ripple voltage.
 [(a) 270 V (b) 27 mA (c) 30 mA (d) 1.11 (e) 130.1 V]
- A dc and an ac voltmeter are used to measure the output voltage of a filter circuit. The readings of the two voltmeters are 50 V and 5 V respectively. Calculate the ripple factor of the filter. [10%]
- In a controlled full-wave rectifier, peak supply voltage is 200 V and load resistance 1 kW. Calculate the power delivered to the load for firing angles of (a) 60° and (b) 120° . [(a) 9.1 W (b) 1.01 W]

OBJECTIVE TESTS – 55

- The ripple factor of a power supply is a measure of
 (a) its filter efficiency
 (b) its voltage regulation
 (c) diode rating
 (d) purity of power output.
- The basic reason why a FW rectifier has twice the efficiency of a HW rectifier is that
 (a) it makes use of a transformer
 (b) its ripple factor is much less
 (c) it utilizes both half-cycle of the input
 (d) its output frequency is double the line frequency.
- The output of a half-wave rectifier is suitable only for
 (a) running car radios
 (b) running ac motors
 (c) charging batteries
 (d) running tape-recorders.
- The ripple factor of a bridge rectifier is
 (a) 0.406 (b) 0.812
 (c) 1.21 (d) 1.11



5. The ripple factor of a power supply is given by (symbols have the usual meaning).
- (a) $\frac{P_{dc}}{P_{ac}}$ (b) $\sqrt{\left(\frac{I_{rms}}{I_{dc}}\right)^2} - 1$
 (c) $\sqrt{\left(\frac{I_{dc}}{I_{rms}}\right)^2} - 1$ (d) $\frac{I_{dc}}{I_{rms}}$
6. The PIV of a half-wave rectifier circuit with a shunt capacitor filter is
 (a) $2V_{sm}$ (b) V_{sm}
 (c) $V_{sm}/2$ (d) $3V_{sm}$
7. The primary function of a rectifier filter is to
 (a) minimise ac input variations
 (b) suppress odd harmonics in the rectifier output
 (c) stabilise dc level of the output voltage
 (d) remove ripples from the rectified output
8. In a rectifier, larger the value of shunt capacitor filter
 (a) larger the $p-p$ value of ripple voltage
 (b) larger the peak current in the rectifying diode
 (c) longer the time that current pulse flows through the diode
 (d) smaller the dc voltage across the load.
9. In a LC filter, the ripple factor,
 (a) increases with the load current
 (b) increases with the load resistance
 (c) remains constant with the load current
 (d) has the lowest value.
10. The main reason why a bleeder resistor is used in a dc power supply is that it
 (a) keeps the supply ON
 (b) improves voltage regulation
 (c) improves filtering action
 (d) both (b) and (c).
11. Which stage of a dc power supply uses a Zener as the main component?
 (a) rectifier (b) voltage divider
 (c) regulator (d) filter.
12. Which rectifier requires four diodes ?
 (a) half-wave voltage doubler
 (b) full-wave voltage doubler
 (c) full-wave bridge circuit
 (d) voltage quadrupler.
13. For a half-wave controlled rectifier, the average value of output dc voltage is given by

- (a) $V_{dc} = \frac{V_m}{2\pi}(1 - \cos \theta_1)$
 (b) $V_{dc} = \frac{2V_m}{\pi}(1 + \cos \theta_1)$
 (c) $V_{dc} = \frac{V_m}{\pi}(\cos \theta_1 - 1)$
 (d) $V_{dc} = \frac{V_m}{2\pi}(\cos \theta_1 + 1)$

14. If, by mistake, ac source in a bridge rectifier is connected across the dc terminals, it will burn out and hence short diodes.
 (a) one (b) two
 (c) three (d) four.
15. The circuit in Fig. 55.55 shows a full-wave rectifier. The input voltage is (rms) single-phase ac. The peak reverse voltage across the diodes D1 and D2 .

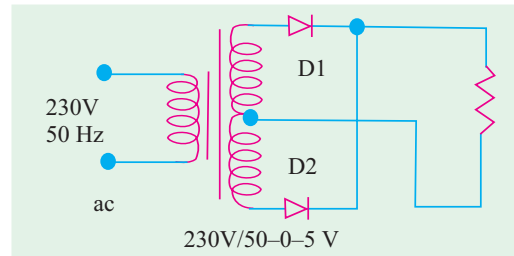

Fig. 55.55

- (a) $100\sqrt{2}$ V (b) 100 V
 (c) $50\sqrt{2}$ V (d) 50V

(GATE ; 2004)

16. The circuit in Fig. 55.56 shows a 3-phase half-wave rectifier. The source is a symmetrical, 3-phase four-wire system. The line-to-line voltage of the source is 100 V. The supply frequency is 400 Hz. The ripple frequency at the output is

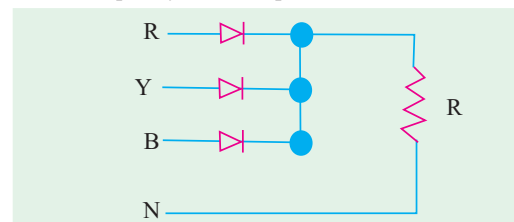

Fig. 55.56

- (a) 400 Hz (b) 800 Hz
 (c) 1200 Hz (d) 2400 Hz

(GATE ; 2004)

ANSWERS

1. (a) 2. (c) 3. (b) 4. (c) 5. (b) 6. (a) 7. (d) 8. (b) 9. (c) 10. (d) 11. (c)
 12. (b) 13. (c) 14. (d) 15. (a) 16. (c)

